



AECOM  
1600 Perimeter Park Drive  
Suite 400  
Morrisville, NC 27560  
www.aecom.com

919 461 1100 tel  
919 461 1123 fax

October 12, 2016

Tennessee Valley Authority  
1101 Market Street  
Chattanooga, Tennessee 37402

**Initial Structural Stability Assessment  
Ash Pond A  
EPA Final CCR Rule  
TVA Gallatin Fossil Plant  
Gallatin, Tennessee**

**1.0 PURPOSE**

This letter documents AECOM's certification of the initial structural stability assessment for the TVA Gallatin Fossil Plant's Ash Pond A. Based on this assessment, the Ash Pond A is in compliance with the structural stability requirements in the Final CCR Rule at 40 CFR 257.73(d).

**2.0 INITIAL STRUCTURAL STABILITY ASSESSMENT**

As described in 40 CFR 257.73(d), documentation is required on how the Ash Pond A has been designed, constructed, operated, and maintained according to the structural stability requirements listed in the section. The combined capacity of all spillways must also be designed, constructed, operated, and maintained to adequately manage flow from the 1000-year storm event based upon a hazard potential classification of "significant."

**3.0 SUMMARY OF FINDINGS**

The attached report presents the initial structural stability assessment of the Ash Pond A. The results show that the impoundment meets the structural stability requirements set forth in 40 CFR 257.73(d)(1)-(2).

Remainder of Page Left Blank Intentionally

**4.0 QUALIFIED PROFESSIONAL ENGINEER CERTIFICATION**

I, Gabriel W. Lang, being a Professional Engineer in good standing in the State of Tennessee, do hereby certify, to the best of my knowledge, information, and belief:

1. that the information contained in this certification is prepared in accordance with the accepted practice of engineering;
2. that the information contained herein is accurate as of the date of my signature below; and
3. that the initial structural stability assessment for the TVA Gallatin Fossil Plant's Ash Pond A meets the requirements specified in 40 CFR 257.73(d)(1)-(2).

SIGNATURE \_\_\_\_\_ DATE 10/12/16  
ADDRESS: AECOM  
1600 Perimeter Park Drive  
Suite 400  
Morrisville, NC 27560  
TELEPHONE: (919) 461 1100  
ATTACHMENTS: Initial Structural Stability Assessment 40 CFR 257.73(d)(1); Existing CCR Surface Impoundments; TVA Gallatin Fossil Plant; Ash Pond A, Middle Pond A, Bottom Ash Pond

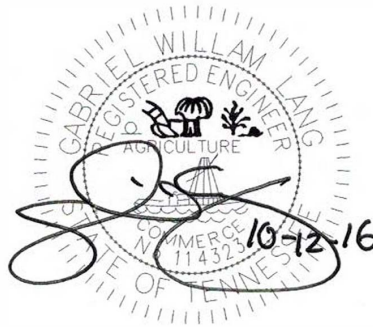

# COAL COMBUSTION PRODUCT DISPOSAL PROGRAM

Tennessee Valley Authority – Ash Pond A, Middle Pond A, Bottom  
Ash Pond  
Sumner County, Tennessee

## Initial Structural Stability Assessment 40 CFR 257.73(d)(1) Existing CCR Surface Impoundments TVA Gallatin Fossil Plant

Prepared for



Tennessee Valley Authority  
1101 Market Street  
Chattanooga, TN 37402-2801

October 12, 2016 – Rev0

Prepared by

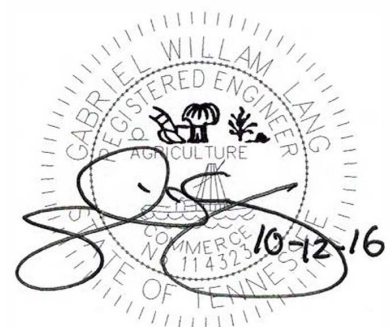



## Table of Contents

1.0	Project Background .....	1
2.0	Structural Stability Assessment - §257.73(d)(1) .....	1
2.1	Foundations and Abutments - §257.73(d)(1)(i) .....	2
2.2	Slope Protection - §257.73(d)(ii) .....	3
2.3	Embankment Dike Compaction - §257.73(d)(1)(iii) .....	3
2.4	Vegetated Slopes - §257.73(d)(1)(iv) .....	4
2.5	Spillway Capacity - §257.73(d)(1)(v) .....	4
2.5.1	Spillway Capacity at Sustained Flows - §257.73(d)(1)(v)(A) .....	4
2.5.2	Spillway Capacity at Peak Discharge - §257.73(d)(1)(v)(B) .....	4
2.6	Hydraulic Structures - §257.73(d)(1)(vi) .....	5
2.6.1	Pipes .....	5
2.6.2	Spillway - Siphon System and Vertical Risers .....	6
2.6.3	Recommendations .....	7
2.7	Sudden Drawdown - §257.73(d)(1)(vii) .....	7
3.0	Conclusion .....	7
4.0	References .....	8

## Figures

Figure 1: Ash Pond Complex

## Photos

Photo – 30” RCP, Typical Spillway at Upstream and Downstream, 02-28-2013

Photo – 48” RCP Risers, Typical Condition of Spillway Risers, 03-04-2013

## Appendices

Appendix A Hydraulic Structures Assessment Calculation Package

## 1.0 Project Background

On April 17, 2015 the “Disposal of Coal Combustion Residuals (CCR) from Electric Utilities” (CCR Rule) was published in the Federal Register. AECOM has been contracted by TVA to analyze the Structural Stability of the Gallatin Fossil Plant’s CCR surface impoundments and evaluate compliance with §257.73 of the CCR Rule.

As required by §257.73 of the EPA Final CCR Rule, an initial structural integrity evaluation is required by October 17, 2016 and must include an initial structural stability assessment for each existing CCR surface impoundment that meets the conditions of paragraph (b) as follows:

1. Has a height of five feet or more and a storage volume of 20 acre-feet or more or
2. Has a height of 20 feet or more.

Ash Pond A and Middle Pond A meet both criteria. Bottom Ash Pond meets the second criteria. A plan view showing the location of Ash Pond A, Middle Pond A, and Bottom Ash Pond is shown in **Figure 1**.

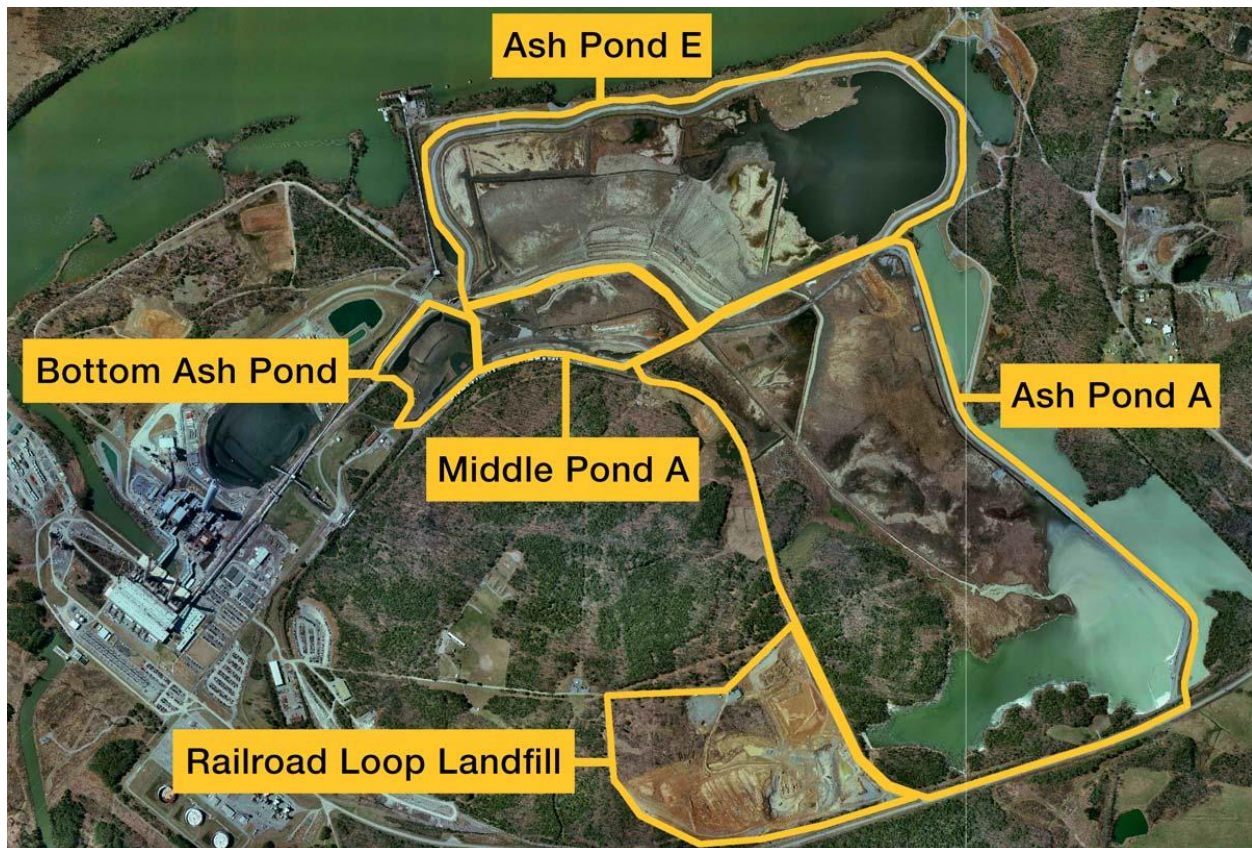

Figure 1: Ash Pond Complex

## 2.0 Structural Stability Assessment - §257.73(d)(1)

**40 CFR 257.73(d)(1).** Periodic structural stability assessments. (1) The owner or operator of the CCR unit must conduct initial and periodic structural stability assessments and document

*whether the design, construction, operation, and maintenance of the CCR unit is consistent with recognized and generally accepted good engineering practices for the maximum volume of CCR and CCR wastewater which can be impounded therein. The assessment must, at a minimum, document whether the CCR unit has been designed, constructed, operated, and maintained with:*

- (i) Stable foundations and abutments;*
- (ii) Adequate slope protection to protect against surface erosion, wave action, and adverse effects of sudden drawdown;*
- (iii) Dikes mechanically compacted to a density sufficient to withstand the range of loading conditions in the CCR unit;*
- (iv) Vegetated slopes of dikes and surrounding areas, except for slopes which have an alternate form or forms of slope protection;*
- (v) A single spillway or a combination of spillways configured as specified in paragraph (d)(1)(v)(A) of this section. The combined capacity of all spillways must be designed, constructed, operated, and maintained to adequately manage flow during and following the peak discharge from the event specified in paragraph (d)(1)(v)(B) of this section.*
- (vi) Hydraulic structures underlying the base of the CCR unit or passing through the dike of the CCR unit that maintain structural integrity and are free of significant deterioration, deformation, distortion, bedding deficiencies, sedimentation, and debris which may negatively affect the operation of the hydraulic structure; and*
- (vii) For CCR units with downstream slopes which can be inundated by the pool of an adjacent water body, such as a river, stream or lake, downstream slopes that maintain structural stability during low pool of the adjacent water body or sudden drawdown of the adjacent water body.*

## **2.1 Foundations and Abutments - §257.73(d)(1)(i)**

The Gallatin Fossil Plant (GAF) is located in the northern portion of central Tennessee along the north bank of the Cumberland River. The geologic map for the area shows soil deposits consisting of alluvial clay, silt and very fine sand across the site. The map indicates a variable thickness of the alluvium that may be as much as 70 feet. The alluvial deposits are mapped primarily at lower site elevations along the power plant area and extend into the southern end of the ash pond complex. The remaining areas are underlain by residual clays resulting from in-place weathering of the parent Ordovician age limestone formations. Therefore, the majority of the ash pond complex is underlain by either alluvial or residual clays.

Specifically, the foundation of the perimeter dikes that surround Ash Pond A, Middle Pond A, and Bottom Ash Pond typically consist of residual clay and the foundation of the divider dikes consists of sluiced ash. The residual clay consisted of moist, yellow to red-brown, medium stiff to stiff, lean clay (CL) and fat clay (CH). The sluiced ash classified as wet, gray and black, loose to medium dense, silty sand (SM), clayey sand (SC), and sandy silt (ML).

A dam assessment and inspection of the Ash Pond Complex which includes Ash Pond A, Middle Pond A, Bottom Ash Pond, and Ash Pond E at GAF was completed in 2013 and 2016, respectively (see references [1] and [2]). Based on the reports, no evidence of structural weakness of the inspected units was observed. No significant signs of tension cracking, settlement, depressions, erosion, and/or deformations at the crest, slope and toe of the dikes were observed. The stability of the slopes has been confirmed through TVA's Instrumentation Program (see reference [3]). No boils or major uncontrollable seepage areas was observed along slopes or toes of the dikes.

Also, an assessment of seepage conditions for Ash Pond A including an evaluation of piping potential of the foundation material was performed; and the results of the assessment were provided in a geotechnical evaluation report dated May 27, 2010, see reference [4]. Seepage analyses were performed at three cross sections across the divider dike using Geoslope, Inc.'s SEEP/W software. As part of that analysis, horizontal and vertical gradients were determined near the toe of the downstream slope. A determination of critical, vertical exit gradients was performed following established sources (including Terzaghi and Peck, USACE EM 1110-2-1901, and USBR Design Standard No. 13 Embankment Dams). Seepage exit gradients determined from the seepage analysis were compared with the critical gradient to calculate a safety factor against piping. For the analyzed cross sections of the Ash Pond A divider dike, the minimum computed safety factor against piping was recorded at 10.8.

A similar analysis was performed as part of the assessment of Middle Pond A and the Bottom Ash Pond, see reference [5]. The factor of safety against piping was found to vary from 3.1 at Middle Pond A to approximately 14 at the Bottom Ash Pond.

Seepage conditions have been analyzed in accordance with acceptable methodologies. All seepage modeling performed indicated a factor of safety against piping of greater than 3, which exceeds the requirement of 3.0 stated in USACE EM 1110-2-1901. Based on existing analytical data and results, the existing embankments and foundation materials are performing acceptably in regard to piping and heave potential in comparison to current criteria. Further, no physical or visual evidence of piping, heave, or uplift has been observed during multiple visits to the site between 2015 and 2016.

## **2.2 Slope Protection - §257.73(d)(ii)**

The slopes along the dikes and divider dikes are generally protected with either dense grass or riprap; no trees or large, bushy vegetation are present on the slopes.

No additional slope protection is required based on anticipated flow velocities.

## **2.3 Embankment Dike Compaction - §257.73(d)(1)(iii)**

Construction documents (see references [6] and [7]) indicate that both the original divider dike and the raised dike for Ash Pond A were mechanically compacted. For the original dike, all trees were cleared in the area and the embankments were constructed of unclassified material placed in layers 12± inches thick and compacted by hauling equipment. For the raised dikes, the embankments were constructed of heavy bottom ash fill placed in 9" maximum loose lifts and

thoroughly compacted with loaded rubber tired earth hauling equipment making a minimum of 6 passes over each layer. The shells of the dikes were constructed of bottom ash fill well compacted in layers with heavy rubber tired equipment.

## 2.4 Vegetated Slopes - §257.73(d)(1)(iv)

The slopes of the dikes and divider dikes that form Ash Pond A, Middle Pond A, and Bottom Ash Pond have been maintained with either dense grass or riprap; no trees or large, bushy vegetation are present on the slopes.

## 2.5 Spillway Capacity - §257.73(d)(1)(v)

Per §257.73(d)(1)(v),

(A) All spillways must be either:

- (1) Of non-erodible construction and designed to carry sustained flows; or
- (2) Earth- or grass-lined and designed to carry short-term, infrequent flows at non-erosive velocities where sustained flows are not expected.

(B) The combined capacity of all spillways must adequately manage flow during and following the peak discharge from a:

- (1) Probable maximum flood (PMF) for a high hazard potential CCR surface impoundment; or
- (2) 1000-year flood for a significant hazard potential CCR surface impoundment; or
- (3) 100-year flood for a low hazard potential CCR surface impoundment.

### 2.5.1 Spillway Capacity at Sustained Flows - §257.73(d)(1)(v)(A)

Middle Pond A and Bottom Ash Pond do not have any spillway features. Ash Pond A has two spillway features: a siphon system during normal operating conditions and three reinforced concrete pipe (RCP) spillway risers during large storm events up to the spillway design flood (SDF). During normal operating conditions, a siphon system consisting of six 18-inch diameter HDPE pipes are used to carry sustained flows from Ash Pond A to Stilling Pond B. Water from Ash Pond A is drawn through the submerged inlet of each siphon, lifted over the divider dike by siphon action, and is discharged downstream into Stilling Pond B.

The siphons are constructed of HDPE which is a non-erodible material that is resistant to the flow of water. The basis of design report and construction documents of the siphons can be seen in references [8] and [9]. According to the hydrologic and hydraulic (H&H) study completed in 2013 (see reference [8]), the spillway is adequate to carry the sustained flows.

### 2.5.2 Spillway Capacity at Peak Discharge - §257.73(d)(1)(v)(B)

Based on the hazard assessment in 2015 (see reference [10]), Ash Pond A has been classified as a significant hazard potential. Therefore, the combined capacity of all spillways in Ash Pond

A must adequately manage flow during and following the peak discharge from a 1000-year flood.

During small to moderate storm events, the siphon operator may adjust the flow rate through the siphon system to pass the storm event using only the siphons. During large storm events up to the 1000-year flood, the three 48-inch RCP vertical spillway risers in Ash Pond A will begin to pass flow along with the siphon system. According to the H&H study completed in 2016 (see reference [11]), the combined capacity of the spillways is adequate to manage the flow during and following the peak discharge from a 1000-year flood.

## 2.6 Hydraulic Structures - §257.73(d)(1)(vi)

Bottom ash is sluiced into the southern portion of Bottom Ash Pond. The bottom ash settles in the Bottom Ash Pond. Process flows travel from the western portion of Bottom Ash Pond through three 48-inch RCPs at the northwest corner into Middle Pond A and from the eastern portion through a 36-inch RCP and a 48-inch corrugated metal pipe (CMP) into the southeast corner of Middle Pond A. Flow in the southeast corner of Middle Pond A is directed through a 48-inch RCP underneath the existing haul road and, thereafter, through two 48-inch CMPs and a 48-inch HDPE pipe from Middle Pond A through a divider dike into Ash Pond A. Then, the process flow is routed through a siphon system consisting of six, 18-inch diameter HDPE pipes from Ash Pond A to Stilling Pond B. Water from Ash Pond A is drawn through the submerged inlet of each siphon, lifted over the divider dike by siphon action, and is discharged downstream into Stilling Pond B. The siphon system operates as the primary spillway during normal operating conditions. During small to moderate storm events, the siphon operator may adjust the flow rate through the siphon system to pass the storm event using only the siphons. During large storm events, the three RCP spillway risers, which discharge through three 30-inch RCP into Stilling Pond B, will begin to pass flow along with the siphon system.

### 2.6.1 Pipes

The existing pipes through the divider dikes between Ash Pond A, Middle Pond A and Bottom Ash Pond have not been inspected since the pipes are currently submerged. The existing pipes through the divider dike between Ash Pond A and Stilling Pond B have been inspected via camera. The interior of those pipes are generally in good condition with some minor to moderate deposit encrustation (see **Photo 14** from February 28, 2013). Minimal longitudinal cracks, chipped joints and joint leaking were also noted in the pipes. Visual inspections of the dikes where pipes pass through do not show any signs of deformation.

The pipes have been evaluated for buckling stability for two different limit states: usual loading conditions associated with regularly occurring pool levels and unusual loading conditions associated with the design flood event. All associated calculations, including the structure's geometry and material properties are included in **Appendix A**. The pipes satisfy the stability checks for the limit states considered.

### 2.6.2 Spillway - Siphon System and Vertical Risers

The spillway consisting of a siphon system and three 48" RCP vertical risers is located at the northeast end of Ash Pond A. The siphon system, as described in **Section 2.5.1**, has been evaluated for structural stability in reference [8] and is shown to satisfy all strength and stability checks.

The original construction drawings were used to determine the dimension of the vertical risers and are provided in **Appendix A**. The risers were all constructed similarly. Each riser is founded on a reinforced concrete pad (6.5ft wide x 6.5ft long x 1.5ft deep). A reinforced concrete junction box (6ft wide x 6ft long x 4ft tall) with 12" wall thickness is attached to the foundation. Two feet lengths of 48" diameter Class III RCP were stacked on the junction box to raise the risers to their current elevations. Construction documents state that pipe joints were to be grouted to form stable and water-tight connections. Each riser was covered with a skimmer composed of a 5-foot section of 120" diameter galvanized CMP with interior steel angle bracing. Water flows southwest to northeast via three 30" diameter RCPs that extend from the junction box of the risers through the divider dike and discharges in Stilling Pond B. The outlet pipes are approximately 156-feet long.

The spillway in Ash Pond A was modified in 2013; see references [8] and [9]. A stainless steel weir ring was added to the top of the risers. The skimmer hoods rest on the weir ring. The risers were stabilized by placing stone around them. In 2015-2016, the water level in Ash Pond A was lowered to elevation 463 ft. Accordingly, sections of the concrete risers were removed and the skimmer reinstalled.

In February to March of 2013, a site inspection to evaluate the condition of the three risers at Ash Pond A was completed. The middle riser was accessed via an adjacent boardwalk. The other risers were accessed by boat. There was no deterioration discovered at the base of the CMP skimmers. Surface rusts were present on the CMP skimmers and associated steel bracings. The areas of the outer concrete risers were not observable due to the water level. The evaluation also included viewing of available videos depicting the condition inside the vertical risers and concrete pipes. Cracking, deterioration or spalling was not detected on the interior of the risers. There were no apparent deteriorations or obstructions to water flow from the top of the risers. **Photos 3-4** taken March 4-5, 2013 from GAF Pond A Spillway Inspection shows the typical condition of the risers. As seen in the photos, small amounts of non-surface water leaks through the riser joints between sections of the risers and the joint between the junction box and vertical riser. This occurs because the riser pipe sections are gravity stacked with no physical connection. Any grout that may have been applied at the joints has deteriorated.

Due to the water level, the outer surface of the pipe outlets couldn't be evaluated. Evaluation of the video recordings showed a clear pathway for the water flow without any obstruction or debris present inside the spillways.

The riser structures were evaluated for two different limit states. The first limit state is associated with regularly occurring pool levels (usual loading conditions). The critical condition

for floatation of the riser structures occurs when the pool level is near the top of the riser structures but does not flow over. It was assumed that the riser structures were not filled with water. The buoyant force was applied at the bottom of the foundation. The critical condition for bearing capacity occurs when the risers are filled with water. Sliding and overturning moment were not checked for this limit state because the structure is subjected to equalized hydrostatic pressure.

The second limit state is associated with loading under the 1000-year flood event (unusual loading conditions). Evaluation for this flood event is required for a structure defined to have a significant hazard potential per CCR Rule. It has been determined that the 1000-year flood event will not overtop the pond dikes, so there will be no stream flow against the side of the riser structures that will cause instability issues. For informational purposes, analyses were completed using the maximum water flow velocity for which the structural stability of the riser structures was satisfied.

The shear and maximum moment in the pipes was also checked for both limit states described above. All associated calculations, including structure geometry and material properties are included in **Appendix A**. The risers and pipes satisfy all strength and stability checks for the limit states considered. Thus, no rehabilitation is required at this time.

### 2.6.3 Recommendations

It was noted earlier that pipe inspections for the pipes that run through the divider dikes between Ash Pond A, Middle Pond A, and Bottom Ash Pond have not been inspected due to the submerged nature of the pipes. Based upon visual observations of the facility and hydraulic modeling, the pipes appear to be performing adequately. As part of future periodic assessments, the condition of the pipes should be confirmed via camera inspections.

## 2.7 Sudden Drawdown - §257.73(d)(1)(vii)

Sudden drawdown from the 1000-year flood at the toe of the divider dike between Ash Pond A and Stilling Ponds B and C will not produce a significant risk of slope failure since the toe of that divider dike is protected with a 10-foot wide riprap bench.

Middle Pond A or Bottom Ash Pond will not experience the sudden drawdown condition because the 100-yr. floodplain of the Cumberland River does not reach the toe of the downstream dike.

## 3.0 Conclusion

Based on the results of the initial structural stability assessment, Ash Pond A, Middle Pond A, and Bottom Ash Pond meet the requirements of the CCR Rule as discussed in **Section 2.0**.

## 4.0 References

- [1] Dewberry Consultants LLC, "Coal Combustion Residue Impoundment, Round 11 - Dam Assessment Report," April 2013.
- [2] TVA, "2016 Intermediate Inspection of CCR facilities at Tennessee Valley Authority's (TVA's) Gallatin Fossil Plant (GAF)," August 1, 2016.
- [3] Stantec and AECOM, "Annual Instrumentation and Monitoring Program Final Report (Rev. 2); Fiscal Year 2015; Tennessee Valley Authority Instrumentation Monitoring Program; Coal Combustion Product (CCP) Storage Facilities; Various Plants Alabama, Kentucky, and Tennessee.," February 5, 2016.
- [4] Stantec Consulting Services Inc., "Report of Geotechnical Exploration and Slope Stability Evaluation, Ash Pond/Stilling Pond Complex, Gallatin Fossil Plant," May 27, 2010.
- [5] AECOM, "Geotechnical Exploration and Analysis, CCR Rule Compliance (Rev. 0), Bottom Ash Pond and Middle Pond A," October 2016.
- [6] Tennessee Valley Authority, "Construction Drawing 10N 273-02 R1," November 7, 1988.
- [7] Tennessee Valley Authority, "Construction Drawing 10N274 R2," June 23, 1986.
- [8] URS, "Basis of Design, Pond A Spillway Upgrade, Gallatin Fossil Plant," August 16, 2013.
- [9] URS, "Pond A Spillway Upgrade Record Drawings," February 27, 2015.
- [10] Stantec Consulting Services Inc., "Hazard Potential Classification Assessment; Ash Pond A; Gallatin Fossil Plant; Sumner County, Tennessee," September 8, 2015.
- [11] AECOM, "Inflow Design Flood Control Plan; Ash Pond A; Gallatin Fossil Plant; Sumner County, Tennessee," October 2016.
- [12] URS, "Basis of Design, Pond A Dike Remediation, Gallatin Fossil Plant," November 6, 2013.
- [13] URS, "Ash Pond A Dike Remediation Record Drawings," January 16, 2015.
- [14] URS, "Ash Pond A and E Dikes, Geotechnical Site Evaluation Report (Rev. 0)," February 21, 2014.
- [15] Stantec Consulting Services Inc., "Report of Breach Analysis for GAF Ash Pond Complex," 2013.
- [16] USACE, "USACE EM 1110-2-1902 Slope Stability," October 31, 2003.
- [17] USBR, "Design Standard No. 13: Embankment Dams," January 2014.
- [18] K. Terzaghi, R. B. Peck and G. Mesri, Soil Mechanics in Engineering Practice, 3rd Edition, New York: John Wiley & Sons, Inc., 1996.
- [19] AECOM, "Inflow Design Flood Control Plan; Middle Pond A; Gallatin Fossil Plant; Sumner County, Tennessee," October 2016.
- [20] AECOM, "Inflow Design Flood Control Plan; Bottom Ash Pond; Gallatin Fossil Plant; Sumner County, Tennessee," October 2016.

PHOTOS

<b>Client Name:</b> Tennessee Valley Authority		<b>Site Location:</b> TVA Gallatin Fossil Plant, Sumner County, TN. GAF Pond A Spillway Inspection	<b>Project No.</b> 31853221
<b>Photo No.</b> <b>3</b>	3.4.13		
<b>Description:</b> East riser interior with buildup scraped away to reveal joints			

<b>Photo No.</b> <b>4</b>	3.5.13	
<b>Description:</b> Middle riser prepped for joint measurements		

<b>Client Name:</b> Tennessee Valley Authority	<b>Site Location:</b> TVA Gallatin Fossil Plant, Sumner County, TN. GAF Pond A Spillway Inspection	<b>Project No.</b> 31853221
---	--	--------------------------------

<b>Photo No.</b> <b>13</b>	2.28.13
-------------------------------	---------

**Description:**  
East spillway barrel  
upstream side



<b>Photo No.</b> <b>14</b>	2.28.13
-------------------------------	---------

**Description:**  
East spillway barrel  
downstream side



APPENDIX A  
HYDRAULIC STRUCTURES ASSESSMENT  
CALCULATION PACKAGE

# Structural Stability Assessment for Riser Structures in Ash Pond A at TVA Gallatin Fossil Plant

Prepared for



Tennessee Valley Authority  
1101 Market Street  
Chattanooga, Tennessee 37402-2801

Prepared by



1000 Corporate Centre Drive, Suite 250  
Franklin, Tennessee 37067-6209

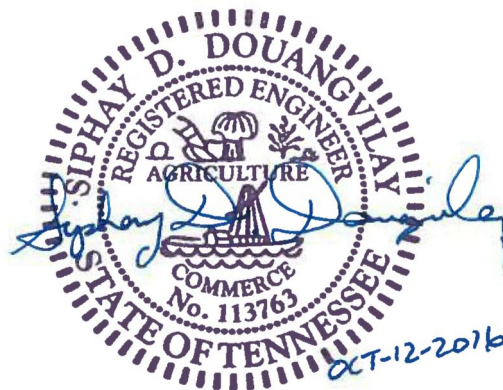

## Discussion

The following calculations detail the structural stability assessment for the existing riser structures in Ash Pond A at Tennessee Valley Authority (TVA) Gallatin Fossil Plant (GAF). The calculations were completed in accordance with United States Environmental Protection Agency's (EPA) requirements under the Hazardous and Solid Waste Management System; Disposal of Coal Combustion Residuals (CCR) from Electric Utilities [RIN-250-AE81; FRL-9149-4] (EPA Final CCR Rule) section 257.73(d).

## References

- 1.) TVA-CCR Rule Template 257.73 (d).
- 2.) Existing drawings listed under Riser and skimmer geometry.
- 3.) URS Ash Pond A and E Dikes Geotechnical Site Evaluation Report (Rev. O), February 21, 2014.
- 4.) USACE EM 1110-2-2100, Stability Analysis of Concrete Structures, December 1, 2005.
- 5.) USACE EM 1110-1-1905, Bearing Capacity of Soils, October 30, 1992.

## Material Properties and Geometry

The material properties and geometry defined below are determined using TVA CCR rule template 257.73(d), existing project drawings, geotechnical data report, historical data, and engineering judgement.

### Soil properties

Unit weight of water	$\gamma_w := 62.4\text{pcf}$
Unit weight of foundation soil	$\gamma_s := 85\text{pcf}$
Friction angle of foundation soil	$\phi_s := 26^\circ$
Cohesion of foundation soil	$c_s := 0\text{psf}$

### Concrete material properties

Reference TVA CCR Rule 257.73(d), 2.1.1

Unit weight of concrete	$\gamma_c := 150\text{pcf}$
Poisson's ratio	$\nu_c := 0.2$
Unconfined compressive strength	$f_c := 3000\text{psi}$ Class A concrete
Shear strength	$\tau_c := 0.10 \times f_c = 300\text{psi}$
Static tensile strength	$f_t := 1.7 \times \frac{f_c}{\text{psi}^{\frac{2}{3}}} = 353.614\text{psi}$
Dynamic tensile strength	$f_{td} := 1.5 \times f_t = 530.421\text{psi}$
Instantaneous elastic modulus	$E_c := 57000 \times \sqrt{f_c} \text{psi} = 3.122 \times 10^6\text{psi}$
Sustained elastic modulus	$E_{cs} := 0.70 \times E_c = 2.185 \times 10^6\text{psi}$

### Reinforcing steel material properties

Reference TVA CCR Rule 257.73(d), 2.1.1

Yield strength	$f_y := 60\text{ksi}$
Elastic modulus	$E_s := 29000\text{ksi}$



Riser and skimmer geometry

Reference:

- 1.) TVA, Ash Disposal Spillway Standard Drawing No. 10N274 dated NOV-4-1969.
- 2.) TVA, Ash Disposal Area No.3 Plan, Sections & Details Drawing No. 10N273-02 dated JUN-23-1986.
- 3.) URS, Pond A Spillway Upgrade Drawing No. 10W279-04 through 10W279-07 dated FEB-27-2015.
- 4.) AECOM, Spillway Modification Details Drawing No. 10W510-9 dated JAN-8-2016.

Figure 1: Riser and Skimmer Details from 10N274

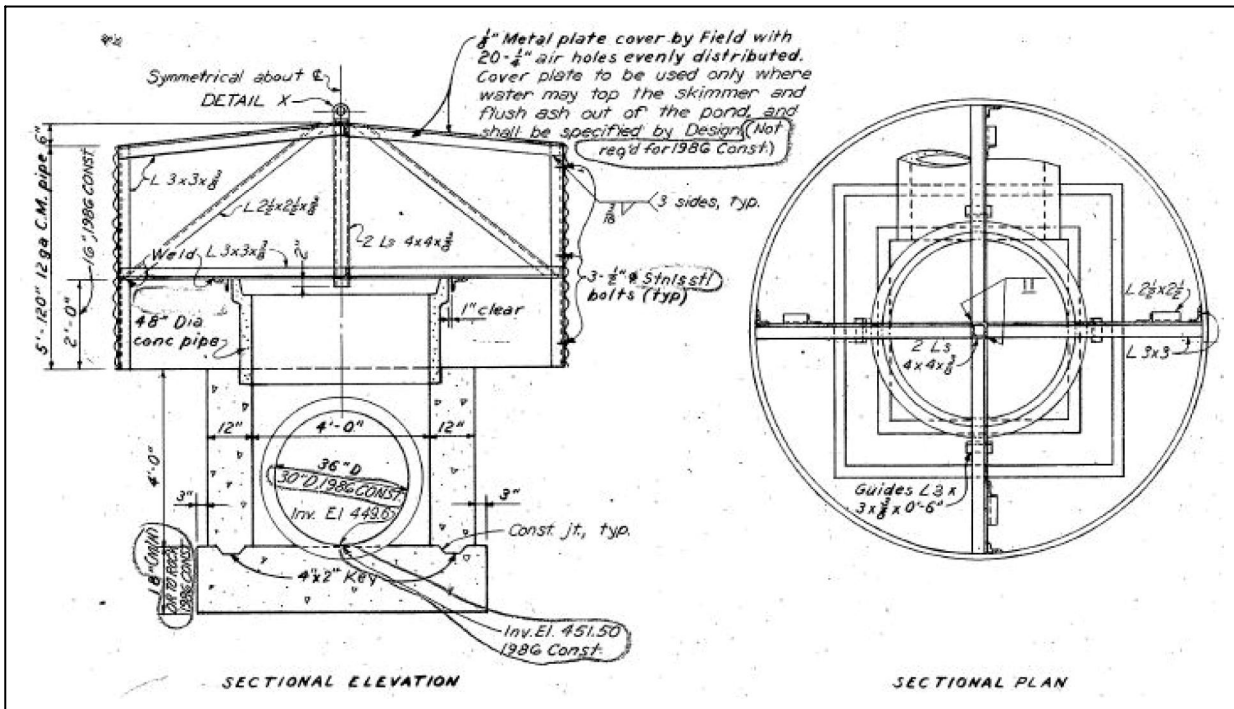
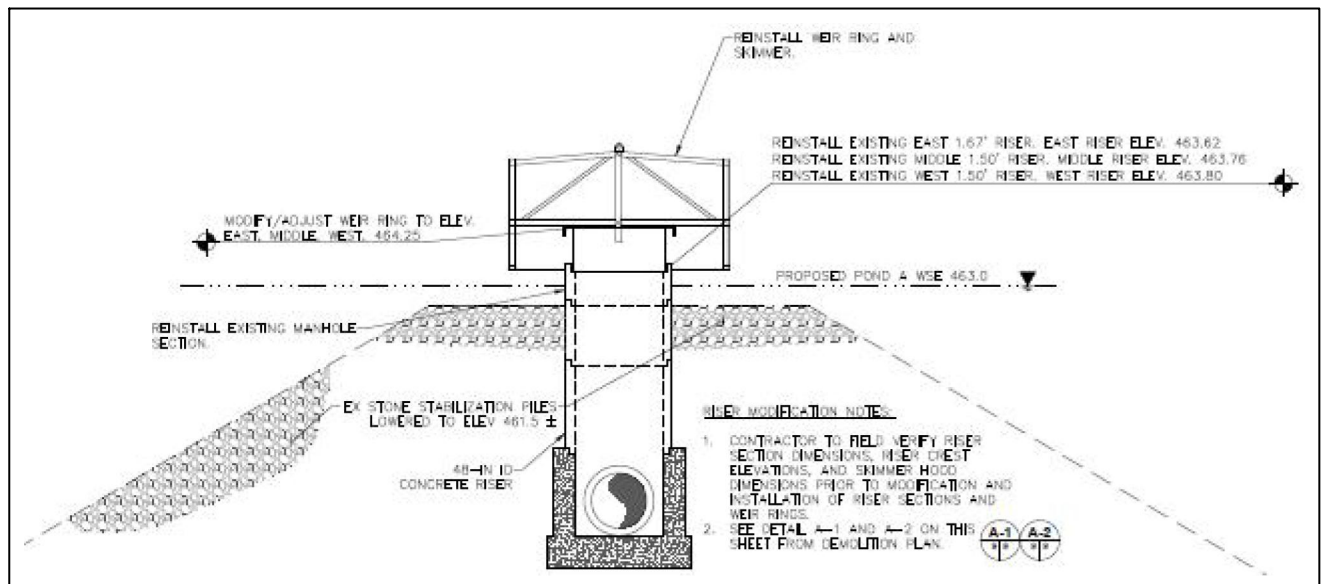

Figure 2: Modified Pond A Spillway Risers from 10W510-9



## Riser geometry

Top elevation of riser structure	$EL_{top} := 464\text{ft}$ (not including skimmer)
Bottom elevation (at top of foundation)	$EL_{bot} := 451.5\text{ft}$
Height of structure	$H_{structure} := EL_{top} - EL_{bot} = 12.5\text{ft}$
Height of water outside (from top of foundation)	$H_{wo} := H_{structure} = 12.5\text{ft}$
Foundation - width of footing	$B_{ftg} := 6.5\text{ft}$
Foundation - length of footing	$L_{ftg} := 6.5\text{ft}$
Foundation - depth of footing	$D_{ftg} := 1.5\text{ft}$
Foundation - volume	$V_{ftg} := B_{ftg} \times L_{ftg} \times D_{ftg} = 63.375\text{ft}^3$
Foundation - weight	$W_{ftg} := V_{ftg} \times \gamma_c = 9.506\text{kip}$
Junction box - external width	$B_{box} := 6.0\text{ft}$
Junction box - wall thickness	$t_{box} := 1.0\text{ft}$
Junction box - height	$h_{box} := 4.0\text{ft}$
Junction box - volume	$V_{box} := \frac{\pi}{4} \times (B_{box}^2 - (B_{box} - 2 \times t_{box})^2) \times h_{box} = 80\text{ft}^3$
Junction box - weight	$W_{box} := V_{box} \times \gamma_c = 12\text{kip}$
Riser pipe - inner diameter	$ID_{rsr} := 4.0\text{ft}$
Riser pipe - thickness	$t_{rsr} := 4.0\text{in}$
Riser pipe - outer diameter	$OD_{rsr} := ID_{rsr} + 2 \times t_{rsr} = 4.667\text{ft}$
Riser pipe - total height	$h_{rsr} := H_{structure} - h_{box} = 8.5\text{ft}$
Riser pipe - cross sectional area	$A_{rsr} := \frac{\pi}{4} \times (OD_{rsr}^2 - ID_{rsr}^2) = 4.538\text{ft}^2$
Riser pipe - volume	$V_{rsr} := A_{rsr} \times h_{rsr} = 38.572\text{ft}^3$
Riser pipe - weight	$W_{rsr} := V_{rsr} \times \gamma_c = 5.786\text{kip}$

Skimmer geometry

Figure 3: Skimmer Modifications - Weir ring details from 10W279-07

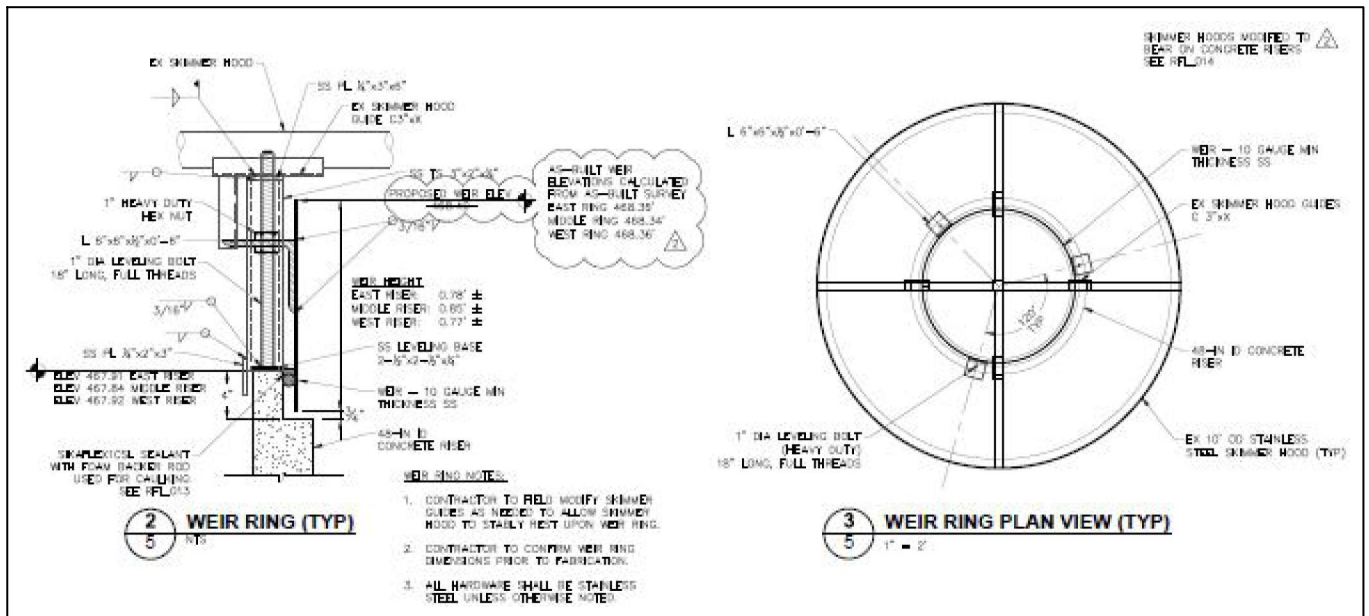

Weir ring - 10 gauge stainless steel sheet

$$\text{unit weight } \gamma_{ss} := 5.67\text{psf}; \text{ height } h_{ss} := 0.78\text{ft}; \text{ length } l_{ss} := 4\text{ft}; \text{ weight } W_{wr1} := \gamma_{ss} \times h_{ss} \times l_{ss} = 17.69\text{ lbf}$$

Weir ring - three 1" diameter leveling bolts

$$\text{quantity } q_b := 3; \text{ unit weight } \gamma_b := 2.7\text{plf}; \text{ length } l_{bolt} := 1.5\text{ft}; \text{ weight } W_{wr2} := q_b \times \gamma_b \times l_{bolt} = 12.15\text{ lbf}$$

Weir ring - three L6x6x1/2 angles

$$\text{quantity } q_a := 3; \text{ unit weight } \gamma_a := 19.6\text{plf}; \text{ length } l_a := 6\text{in}; \text{ weight } W_{wr3} := q_a \times \gamma_a \times l_a = 29.4\text{ lbf}$$

Skimmer - 120" diameter 12 gauge corrugated metal pipe

$$\text{unit weight } \gamma_{cmp} := 183\text{plf}; \text{ length } l_{cmp} := 5\text{ft}; \text{ weight } W_{s1} := \gamma_{cmp} \times l_{cmp} = 915\text{ lbf}$$

Skimmer - L2.5x2.5x3/8 angle

$$\text{unit weight } \gamma_{a1} := 5.9\text{plf}; \text{ length } l_{a1} := 23\text{ft}; \text{ weight } W_{s2} := \gamma_{a1} \times l_{a1} = 135.7\text{ lbf}$$

Skimmer - L3x3x3/8 angle

$$\text{unit weight } \gamma_{a2} := 7.2\text{plf}; \text{ length } l_{a2} := 67\text{ft}; \text{ weight } W_{s3} := \gamma_{a2} \times l_{a2} = 482.4\text{ lbf}$$

Skimmer - L4x4x3/8 angle

$$\text{unit weight } \gamma_{a3} := 9.8\text{plf}; \text{ length } l_{a3} := 8\text{ft}; \text{ weight } W_{s4} := \gamma_{a3} \times l_{a3} = 78.4\text{ lbf}$$

Weight of skimmer and weir ring plus 1% for miscellaneous steel

$$W_{skmr} := (1 + 1\%) \times (W_{wr1} + W_{wr2} + W_{wr3} + W_{s1} + W_{s2} + W_{s3} + W_{s4}) = 1.687 \times \text{kip}$$

### **Floatation Stability - Usual Load Condition**

Floatation stability evaluation is based on current criteria published in U.S. Army Corps of Engineers (USACE) EM 1110-2-2100, Stability Analysis of Concrete Structures. For floatation stability, the following minimum allowable safety factors for the usual and unusual loading conditions are required.

Table 1: Floatation Stability Minimum Allowable Factor of Safety

Load Condition	Minimum allowable factor of safety
Usual Load Condition	$FS_{FL\_u} := 1.3$
Unusual Load Condition	$FS_{FL\_un} := 1.2$

Weight of structure  $W_s := W_{ftg} + W_{box} + W_{rsr} + W_{skmr} = 28.979 \text{ kip}$   
 Weight of water contained within structure  $W_c := 0 \text{ kip}$  (Assume worse case with no water in structure)  
 Surcharge loads  $S := 0 \text{ kip}$   
 Weight of water above top surface of structure  $W_G := 0 \text{ kip}$

Calculate uplift force

Weight of water displaced by foundation  $W_{wd\_ftg} := \gamma_w \times V_{ftg} = 3.955 \text{ kip}$   
 Weight of water displaced by junction box  $W_{wd\_box} := \gamma_w \times B_{box}^2 \times h_{box} = 8.986 \text{ kip}$   
 Weight of water displaced by riser pipe  $W_{wd\_rsr} := \gamma_w \times \frac{\pi}{4} \times OD_{rsr}^2 \times h_{rsr} = 9.072 \text{ kip}$   
 Uplift force  $U := W_{wd\_ftg} + W_{wd\_box} + W_{wd\_rsr} = 22.012 \text{ kip}$

Floatation stability safety factor  $FS_{FL} := \frac{W_s + W_c + S}{U - W_G} = 1.32$  must be  $\geq FS_{FL\_u} = 1.3$

Check floatation safety factor for Usual Load Condition

$checkFS_{FL} := \begin{cases} \text{"Satisfactory"} & \text{if } FS_{FL} \geq FS_{FL\_u} \\ \text{"No Good"} & \text{otherwise} \end{cases} = \text{"Satisfactory"}$

### **Bearing Capacity - Usual Load Condition**

The bearing capacity evaluation is based on current criteria published in U.S. Army Corps of Engineers (USACE) EM 1110-2-2100, Stability Analysis of Concrete Structures. For bearing capacity, the following minimum allowable safety factors for the usual and unusual loading conditions are required.

Table 2: Bearing Capacity Minimum Allowable Factor of Safety

Load Condition	Minimum allowable factor of safety
Usual Load Condition	$FS_{BC\_u} := 3.0$
Unusual Load Condition	$FS_{BC\_un} := 2.6$

Recall foundation soil parameters

Unit weight of foundation soil  $\gamma_s = 85 \text{ pcf}$

Friction angle of foundation soil  $\phi_s = 26^\circ$

Cohesion of foundation soil  $c_s = 0 \text{ psf}$

Recall foundation dimensions

Foundation - width of footing  $B_{ftg} = 6.5 \text{ ft}$

Foundation - length of footing  $L_{ftg} = 6.5 \text{ ft}$

Foundation - depth of footing  $D_{ftg} = 1.5 \text{ ft}$

Depth to base of foundation  $D := 461.5 \text{ ft} - EL_{bot} - D_{ftg} = 8.5 \text{ ft}$

Depth from ground surface to water  $D_w := 0 \text{ ft}$

Inclined load angle  $\theta := 0^\circ$

#### Bearing Capacity and Correction Factors based on USACE EM 1110-1-1905, Table 4-3

$$N_\phi := \tan^2 \left( 45^\circ + \frac{\phi_s}{2} \right) = 2.561$$

$$N_q := N_\phi \times e^{\pi \tan(\phi_s)} = 11.854$$

$$N_c := (N_q - 1) \times \cot(\phi_s) = 22.254$$

$$N_\gamma := (N_q - 1) \times \tan(1.4 \times \phi_s) = 8.002$$

Shape factors

cohesion  $\zeta_{cs} := 1 + 0.2 \times N_\phi \times \frac{B_{ftg}}{L_{ftg}} = 1.512$  ; wedge  $\zeta_{\gamma s} := 1 + 0.1 \times N_\phi \times \frac{B_{ftg}}{L_{ftg}} = 1.256$  ;

surcharge  $\zeta_{qs} := 1 + 0.1 \times N_\phi \times \frac{B_{ftg}}{L_{ftg}} = 1.256$

### **Bearing Capacity - Usual Load Condition (continued)**

Inclined loading factors

$$\text{cohesion } \zeta_{ci} := \frac{\alpha}{e} - \frac{\theta}{90^\circ} \frac{\sigma^2}{\phi} = 1 \quad ; \quad \text{wedge } \zeta_{\gamma i} := \frac{\alpha}{e} - \frac{\theta}{\phi_s} \frac{\sigma^2}{\phi} = 1 \quad ; \quad \text{surcharge } \zeta_{qi} := \frac{\alpha}{e} - \frac{\theta}{\phi_s} \frac{\sigma^2}{\phi} = 1$$

Foundation depth factors

$$\text{cohesion } \zeta_{cd} := 1 + 0.2 \times N_\phi^2 \times \frac{D}{B_{ftg}} = 1.419 \quad ; \quad \text{wedge } \zeta_{\gamma d} := 1 + 0.1 \times N_\phi^2 \times \frac{D}{B_{ftg}} = 1.209 \quad ;$$

$$\text{surcharge } \zeta_{qd} := 1 + 0.1 \times N_\phi^2 \times \frac{D}{B_{ftg}} = 1.209$$

Correction factors

$$\text{cohesion } \zeta_c := \zeta_{cs} \times \zeta_{ci} \times \zeta_{cd} = 2.145 \quad ; \quad \text{wedge } \zeta_\gamma := \zeta_{\gamma s} \times \zeta_{\gamma i} \times \zeta_{\gamma d} = 1.519 \quad ; \quad \text{surcharge } \zeta_q := \zeta_{qs} \times \zeta_{qi} \times \zeta_{qd} = 1.519$$

$$\text{Ultimate bearing capacity} \quad q_u := c_s \times N_c \times \zeta_c + \frac{1}{2} \times B_{ftg} \times (\gamma_s - \gamma_w) \times N_\gamma \times \zeta_\gamma + (\gamma_s - \gamma_w) \times D \times N_q \times \zeta_q = 4.352 \text{ksf}$$

$$\text{Net bearing capacity} \quad q_{net} := q_u - (\gamma_s - \gamma_w) \times D = 4.16 \text{ksf}$$

$$\text{Weight of structure} \quad W_s = 28.979 \text{kip}$$

Weight of water contained within structure (Assume worst case with water filled in structure)

$$\text{Weight of water inside junction box} \quad W_{wc\_box} := \gamma_w \times (B_{box} - 2 \times h_{box})^2 \times h_{box} = 3.994 \text{kip}$$

$$\text{Weight of water inside riser} \quad W_{wc\_rsr} := \gamma_w \times \frac{\pi}{4} \times D_{rsr}^2 \times h_{rsr} = 6.665 \text{kip}$$

$$\text{Total weight of water contained in structure} \quad W_C := W_{wc\_box} + W_{wc\_rsr} = 10.659 \text{kip}$$

$$\text{Total applied pressure (ignoring uplift pressure)} \quad q_{applied} := \frac{W_s + W_C}{B_{ftg} \times L_{ftg}} = 0.938 \text{ksf}$$

$$\text{Bearing capacity safety factor} \quad FS_{BC} := \frac{q_{net}}{q_{applied}} = 4.43 \quad \text{must be } \geq FS_{BC\_u} = 3$$

Check bearing capacity for Usual Load Condition

$$\text{checkFS}_{BC} := \begin{cases} \text{"Satisfactory"} & \text{if } FS_{BC} \geq FS_{BC\_u} \\ \text{"No Good"} & \text{otherwise} \end{cases} = \text{"Satisfactory"}$$

### **Sliding Stability- Unusual Load Condition**

The sliding stability evaluation is based on current criteria published in U.S. Army Corps of Engineers (USACE) EM 1110-2-2100, Stability Analysis of Concrete Structures. For sliding stability, the following minimum allowable safety factors for the usual and unusual loading conditions are required.

Table 3: Sliding Stability Minimum Allowable Factor of Safety

<u>Load Condition</u>	<u>Minimum allowable factor of safety</u>
Usual Load Condition	$FS_{SL\_u} := 2.0$
Unusual Load Condition	$FS_{SL\_un} := 1.5$

Calculate lateral drag force on side of riser structure. For submerged condition, the riser is assumed to be subjected to flood water flow.

Assumed maximum flood water velocity  $V_{max} := 5 \frac{ft}{s}$

Drag coefficient  $C_D := 1.25$  (USACE - drag coefficient not less than 1.25)

Density of water  $\rho := 1.937 \frac{slug}{ft^3}$

Height of riser structure with skimmer  $H_{eff} := H_{structure} + D_{fig} + 3ft = 17ft$  (skimmer top is 3' above riser top)

Frontal area (face of riser)

$$A_{fa} := B_{fig} \times D_{fig} + B_{box} \times h_{box} + OD_{rsr} \times (h_{rsr} - 3ft) + 10ft \times A_{cmp} = 109.417 ft^2$$

Lateral drag force on riser  $F_D := C_D \frac{1}{2} \rho \times V_{max}^2 \times A_{fa} = 3.312 kip$

Normal force  $F_N := W_s + W_C + S + W_G - U = 17.626 kip$

Sliding stability safety factor  $FS_{SL} := \frac{c_s \times B_{fig} \times L_{fig} + F_N \times \tan(\phi_s)}{F_D} = 2.6$  must be  $\geq FS_{SL\_un} = 1.5$

Check sliding stability for Unusual Load Condition

$$checkFS_{SL} := \begin{cases} \text{"Satisfactory"} & \text{if } FS_{SL} \geq FS_{SL\_un} \\ \text{"No Good"} & \text{otherwise} \end{cases} = \text{"Satisfactory"}$$



### **Overturning Stability- Unusual Load Condition**

The overturning stability evaluation is based on current criteria published in U.S. Army Corps of Engineers (USACE) EM 1110-2-2100, Stability Analysis of Concrete Structures. For overturning stability, the following criteria for the usual and unusual loading conditions are required.

Table 4: Overturning Stability Acceptance criteria

<u>Load Condition</u>	<u>Acceptance criteria</u>
Usual Load Condition	100% base in compression
Unusual Load Condition	75% base in compression, resultant within base

Overturning moment due to lateral drag force  $M_D := F_D \times \frac{H_{eff}}{2} = 28.148 \times \text{ft} \cdot \text{kip}$

Eccentricity (resultant from center of foundation)  $ecc := \frac{M_D}{F_N} = 1.597 \text{ ft}$

check if eccentricity is within middle 1/3 of foundation  $\frac{B_{ftg}}{6} = 1.083 \text{ ft}$

$$check_{ecc} := \begin{cases} \text{"100% base in compression"} & \text{if } ecc \leq \frac{B_{ftg}}{6} \\ \text{"Less than 100% base in compression"} & \text{otherwise} \end{cases} = \text{"Less than 100% base in compression"}$$

Sum moments about toe of riser  $M_O := -M_D + F_N \times \frac{B_{ftg}}{2} = 29.136 \times \text{ft} \cdot \text{kip}$

Resultant distance from toe of riser  $x_R := \frac{M_O}{F_N} = 1.653 \text{ ft}$

Resultant ratio  $x_{R\_ratio} := \frac{x_R}{B_{ftg}} = 0.254$

Base area in compression (USACE EM 1110-2-2502, Figure 4-4)  $base_c := 3 \times x_{R\_ratio} = 76\%$

Check overturning percent base in compression acceptance criteria for Unusual Load Condition

$$check_{base_c} := \begin{cases} \text{"Satisfactory"} & \text{if } base_c \geq 75\% \\ \text{"No Good"} & \text{otherwise} \end{cases} = \text{"Satisfactory"}$$

Check overturning resultant acceptance criteria for Unusual Load Condition

$$check_{rslt} := \begin{cases} \text{"Satisfactory, resultant within base"} & \text{if } 0 \text{ ft} \leq x_R \leq B_{ftg} \\ \text{"No good, resultant outside base"} & \text{otherwise} \end{cases} = \text{"Satisfactory, resultant within base"}$$

### **Bearing Capacity - Unusual Load Condition**

Maximum bearing pressure for  $e < \frac{B}{6}$   $Q_{max} := \frac{2F_N}{3L_{ftg} \left( \frac{B}{e} - \frac{e}{B} \right)} = 1.094 \text{ ksf}$

Bearing capacity safety factor  $FS_{bc} := \frac{q_{net}}{Q_{max}} = 3.8$  must be  $\geq FS_{BC\_un} = 2.6$

Check bearing capacity for Unusual Load Condition

$$check_{FS_{bc}} := \begin{cases} \text{"Satisfactory"} & \text{if } FS_{bc} \geq FS_{BC\_un} \\ \text{"No Good"} & \text{otherwise} \end{cases} = \text{"Satisfactory"}$$

### **Check Riser Does Not Tip Over - Unusual Load Condition**

Overtipping moment due to lateral drag force  $M_{O\_LD} := F_D \left( \frac{h_{eff}}{2} - D_{ftg} - h_{box} \right) = 9.935 \text{ ft-kip}$

Resisting moment from weight of riser and skimmer  $M_T := (W_{skmr} + W_{rsr}) \times \frac{OD_{rsr}}{2} = 17.437 \text{ ft-kip}$

Check riser does not tip over for Unusual Load Condition

$$check_{riser} := \begin{cases} \text{"Satisfactory, riser does not tip over"} & \text{if } M_T \geq M_{O\_LD} \\ \text{"No Good"} & \text{otherwise} \end{cases} = \text{"Satisfactory, riser does not tip over"}$$

### **Check Shear and Maximum Moment in Risers - Unusual Load Condition**

Define load and resistance factors based on ACI 350 (conservatively use plain concrete values)  
 shear reduction factor  $\phi_c := 0.55$ ; bending moment reduction factor  $\phi_b := 0.55$

load factor for fluids FL := 1.4

Maximum factored shear load  $V_u := FL \times F_D = 4.636 \text{ kip}$

Shear capacity of riser  $V_c := \phi_c \times 0.10 \times f_c \times A_{rsr} = 107.819 \text{ kip}$

check shear capacity  $\text{check}V_c := \begin{cases} \text{"Satisfactory"} & \text{if } V_c \geq V_u \\ \text{"No good"} & \text{otherwise} \end{cases}$

Maximum factored moment load  $M_u := FL \times M_{o\_LD} = 13.909 \text{ ft} \times \text{kip}$

Section modulus of riser  $S_{x\_rsr} := \frac{\frac{\pi}{64} \times OD_{rsr}^4 - ID_{rsr}^4}{\frac{OD_{rsr}}{2}} = 4.592 \text{ ft}^3$

Moment capacity in compression  $M_{cc} := \phi_b \times f_c \times S_{x\_rsr} = 1091.03 \text{ ft} \times \text{kip}$

Moment capacity in tension  $M_{ct} := \phi_b \times f_t \times S_{x\_rsr} = 128.601 \text{ ft} \times \text{kip}$

check moment capacity  $\text{check}M_c := \begin{cases} \text{"Satisfactory"} & \text{if } \min(M_{cc}, M_{ct}) \geq M_u \\ \text{"No good"} & \text{otherwise} \end{cases}$

### Check Shear and Maximum Moment in Pipes - Usual Condition

Inner diameter of pipe,  $ID_p := 30\text{in}$

Wall thickness of pipe,  $t_{wp} := 3.5\text{in}$

Outer diameter of pipe,  $OD_p := ID_p + 2 \times t_{wp} = 37\text{in}$

Area of pipe,  $A_p := \frac{\pi}{4} \times OD_p^2 - ID_p^2 = 2.558\text{ft}^2$

Unit weight of dike embankment,  $\gamma_{emb} := 120\text{pcf}$

Height of dike embankment,  $H_{emb} := 25\text{ft}$

Depth from top of dike to water level,  $dw := 10.5\text{ft}$  (top of dike at EL 475', normal pool at EL 463')

Vertical arching factor,  $VAF := 1.45$

Effective length of pipe,  $L_e := 1\text{ft}$

Load due to earth pressure,  $W_e := VAF \times \gamma_{emb} \times OD_p \times H_{emb} = 13.412 \times \frac{\text{kip}}{\text{ft}}$

Force from earth pressure,  $F_{W_e} := W_e \times L_e = 13.413 \times \text{kip}$

Load due to water,  $W_D := \gamma_w \times OD_p \times (H_{emb} - dw) = 2.79 \times \frac{\text{kip}}{\text{ft}}$

Force from water,  $F_{D_p} := W_D \times L_e = 2.79 \times \text{kip}$

Moment load due to earth pressure,  $M_{o\_Fwe} := \frac{W_e \times L_e^2}{8} = 1.677 \times \text{ft} \times \text{kip}$

Moment load due to water,  $M_{o\_Fdp} := \frac{W_D \times L_e^2}{8} = 0.349 \times \text{ft} \times \text{kip}$

Define load and resistance factors based on ACI 350 (conservatively use plain concrete values)  
 shear reduction factor  $\phi_c = 0.55$  ; bending moment reduction factor  $\phi_b = 0.55$

Maximum factored shear load

$$V_{u_p} := \max(1.4 \times F_{D_p}, 1.2 \times F_{D_p} + 1.6 \times F_{W_e}) = 24.808 \times \text{kip}$$

Shear capacity of pipe

$$V_{c_p} := \phi_c \times 0.10 \times A_p = 60.778 \times \text{kip}$$

check shear capacity

$$\text{check } V_{c_p} := \begin{cases} \text{"Satisfactory"} & \text{if } V_{c_p} \geq V_{u_p} \\ \text{"No good"} & \text{otherwise} \end{cases}$$

Maximum factored moment load

$$M_{u_p} := \max(1.4 \times M_{o\_Fdp}, 1.2 \times M_{o\_Fdp} + 1.6 \times M_{o\_Fwe}) = 3.101 \times \text{ft} \times \text{kip}$$

Section modulus of riser

$$S_{x_p} := \frac{\frac{\pi}{64} \times OD_p^4 - ID_p^4}{\frac{OD_p}{2}} = 1.634 \times \text{ft}^3$$

Moment capacity in compression  $M_{cc_p} := \phi_b \times f_c \times S_{x_p} = 388.247 \times \text{ft} \times \text{kip}$

Moment capacity in tension

$$M_{ct_p} := \phi_b \times f_t \times S_{x_p} = 45.763 \times \text{ft} \times \text{kip}$$

check moment capacity

$$\text{check } M_{c_p} := \begin{cases} \text{"Satisfactory"} & \text{if } \min(M_{cc_p}, M_{ct_p}) \geq M_{u_p} \\ \text{"No good"} & \text{otherwise} \end{cases}$$

### **Check Shear and Maximum Moment in Pipes - Unusual Condition**

Depth from top of dike to water level,  $dw_{un} := 5.5 \text{ ft}$  (top of dike at EL 475', flood pool at EL 468')

$$\text{Load due to water, } W_{D_{un}} := \gamma_w \times OD_p \times (H_{emb} - dw_{un}) = 1 \times \frac{\text{kip}}{\text{ft}}$$

$$\text{Force from water, } F_{D_{p_{un}}} := W_{D_{un}} \times L_e = 3.752 \times \text{kip}$$

$$\text{Moment load due to earth pressure, } M_{O_{Fwe}} = 1.677 \times \text{ft} \times \text{kip}$$

$$\text{Moment load due to water, } M_{O_{Fdp_{un}}} := \frac{W_{D_{un}} \times L_e^2}{8} = 0.469 \times \text{ft} \times \text{kip}$$

Define load and resistance factors based on ACI 350 (conservatively use plain concrete values)

shear reduction factor  $\phi_c = 0.55$  ; bending moment reduction factor  $\phi_b = 0.55$

$$\text{Maximum factored shear load } V_{u_{p_{un}}} := \max(1.4 \times F_{D_{p_{un}}}, 1.2 \times F_{D_{p_{un}}} + 1.6 \times F_{W_e}) = 25.962 \times \text{kip}$$

$$\text{Shear capacity of pipe } V_{c_p} = 60.778 \times \text{kip}$$

$$\text{check shear capacity } \text{check} V_{c_{p_{un}}} := \begin{cases} \text{"Satisfactory"} & \text{if } V_{c_p} \geq V_{u_{p_{un}}} \\ \text{"No good"} & \text{otherwise} \end{cases} = \text{"Satisfactory"}$$

Maximum factored moment load

$$M_{u_{p_{un}}} := \max(1.4 \times M_{O_{Fdp_{un}}}, 1.2 \times M_{O_{Fdp_{un}}} + 1.6 \times M_{O_{Fwe}}) = 3.245 \times \text{ft} \times \text{kip}$$

$$\text{Moment capacity in compression } M_{cc_p} = 388.247 \times \text{ft} \times \text{kip}$$

$$\text{Moment capacity in tension } M_{ct_p} = 45.763 \times \text{ft} \times \text{kip}$$

check moment capacity

$$\text{check} M_{c_{p_{un}}} := \begin{cases} \text{"Satisfactory"} & \text{if } \min(M_{cc_p}, M_{ct_p}) \geq M_{u_{p_{un}}} \\ \text{"No good"} & \text{otherwise} \end{cases} = \text{"Satisfactory"}$$

# Structural Stability Assessment for Pipe Structures in Middle Pond A and Bottom Ash Pond at TVA Gallatin Fossil Plant

Prepared for



Tennessee Valley Authority  
1101 Market Street  
Chattanooga, Tennessee 37402-2801

Prepared by



1000 Corporate Centre Drive, Suite 250  
Franklin, Tennessee 37067-6209

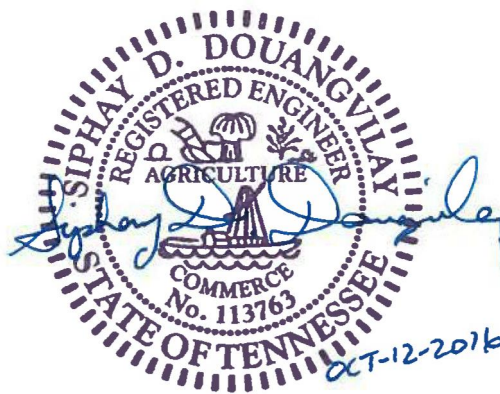

## Discussion

The following calculations detail the structural stability assessment for the existing pipe structures in Bottom Ash Pond and Middle Pond A at Tennessee Valley Authority (TVA) Gallatin Fossil Plant (GAF). Bottom ash is sluiced into the southern portion of Bottom Ash Pond. The bottom ash settles in the Bottom Ash Pond. Process flows travel from the western portion of Bottom Ash Pond through three 48-inch RCPs at the northwest corner into Middle Pond A and from the eastern portion through a 36-inch RCP and a 48-inch corrugated metal pipe (CMP) into the southeast corner of Middle Pond A. Flow in the southeast corner of Middle Pond A is directed through a 48" RCP through the existing haul road and, thereafter, through two 48-inch CMPs and a 48-inch HDPE pipe from Middle Pond A through a divider dike into Ash Pond A. Then, the process flow is routed through a siphon system consisting of six, 18-inch diameter HDPE pipes from Ash Pond A to Stilling Pond B. Water from Ash Pond A is drawn through the submerged inlet of each siphon, lifted over the divider dike by siphon action, and is discharged downstream into Stilling Pond B. The siphon system operates as the primary spillway during normal operating conditions. During small to moderate storm events, the siphon operator may adjust the flow rate through the siphon system to pass the storm event using only the siphons. During large storm events, the three RCP spillway risers, which discharge through three 30-inch RCP into Stilling Pond B, will begin to pass flow along with the siphon system.

The calculations were completed in accordance with United States Environmental Protection Agency's (EPA) requirements under the Hazardous and Solid Waste Management System; Disposal of Coal Combustion Residuals (CCR) from Electric Utilities [RIN-250-AE81; FRL-9149-4] (EPA Final CCR Rule) section 257.73(d).

The CMPs were checked for adequate cover above the pipes. Manufacturer literature requires minimum 12 inches of cover and provides maximum cover of 48-inch CMP to be about 62 feet. The CMPs in both Bottom Ash Pond and Middle Pond A have adequate cover.

## References

- 1.) TVA-CCR Rule Template 257.73 (d).
- 2.) URS Ash Haul Road A Drawing No. 10W263-07 dated September 26, 2014.
- 3.) AWWA M55 - PE Pipe Design and Installation, January 1, 2006.

## Material Properties and Geometry

The material properties and geometry defined below are determined using TVA CCR rule template 257.73(d), existing project drawings, geotechnical data report, historical data, and engineering judgement.

### Soil properties

Unit weight of water	$\gamma_w := 62.4 \text{pcf}$
Unit weight of foundation soil	$\gamma_s := 105 \text{pcf}$
Friction angle of foundation soil	$\phi_s := 34^\circ$
Cohesion of foundation soil	$c_s := 0 \text{psf}$

### Concrete properties

Compressive strength	$f_c := 3000 \text{psi}$
Static tensile strength	$f_t := 1.7 \text{psi} \times \left( \frac{f_c}{\text{psi}} \right)^{\frac{2}{3}} = 353.614 \text{psi}$



**48-inch RCP Northwest corner of Bottom Ash Pond to Middle Pond A**

**Check Shear and Maximum Moment in Pipes - Usual Condition**

Inner diameter of pipe,  $ID_p := 48\text{in}$       Wall thickness of pipe,  $t_{wp} := 5.75\text{in}$   
 Outer diameter of pipe,  $OD_p := ID_p + 2 \times t_{wp} = 59.5\text{in}$       Area of pipe,  $A_p := \frac{\pi}{4} \times (OD_p^2 - ID_p^2) = 6.743\text{ft}^2$   
 Unit weight of dike embankment,  $\gamma_{emb} := 120\text{pcf}$       Height of dike embankment,  $H_{emb} := 25\text{ft}$   
 Depth from top of dike to water level,  $dw := 12\text{ft}$  (top of dike at EL 490.5', normal pool at EL 478.5')  
 Vertical arching factor,  $VAF := 1.45$       Effective length of pipe,  $L_e := 1\text{ft}$

Load due to earth pressure,  $W_e := VAF \times \gamma_{emb} \times OD_p \times H_{emb} = 21.569 \times \frac{\text{kip}}{\text{ft}}$

Force from earth pressure,  $F_{W_e} := W_e \times L_e = 21.569 \times \text{kip}$

Load due to water,  $W_D := \gamma_w \times OD_p \times (H_{emb} - dw) = 4.022 \times \frac{\text{kip}}{\text{ft}}$

Force from water,  $F_{D_p} := W_D \times L_e = 4.022 \times \text{kip}$

Moment load due to earth pressure,  $M_{O\_Fwe} := \frac{W_e \times L_e^2}{8} = 2.696 \times \text{ft} \times \text{kip}$

Moment load due to water,  $M_{O\_Fdp} := \frac{W_D \times L_e^2}{8} = 0.503 \times \text{ft} \times \text{kip}$

Define load and resistance factors based on ACI 350 (conservatively use plain concrete values)  
 shear reduction factor  $\phi_c := 0.55$ ; bending moment reduction factor  $\phi_b := 0.55$

Maximum factored shear load  $V_{u_p} := \max(1.4 \times F_{D_p}, 1.2 \times F_{D_p} + 1.6 \times F_{W_e}) = 39.337 \times \text{kip}$

Shear capacity of pipe  $V_{c_p} := \phi_c \times 0.10 \times f_c \times A_p = 160.206 \times \text{kip}$

check shear capacity  $\text{check } V_{c_p} := \begin{cases} \text{"Satisfactory"} & \text{if } V_{c_p}^3 \geq V_{u_p}^3 \\ \text{"No good"} & \text{otherwise} \end{cases}$

Maximum factored moment load  $M_{u_p} := \max(1.4 \times M_{O\_Fdp}, 1.2 \times M_{O\_Fdp} + 1.6 \times M_{O\_Fwe}) = 4.917 \times \text{ft} \times \text{kip}$

Section modulus of riser  $S_{x_p} := \frac{\frac{\pi}{64} \times (OD_p^4 - ID_p^4)}{\frac{OD_p}{2}} = 6.899 \times \text{ft}^3$

Moment capacity in compression  $M_{cc_p} := \phi_b \times f_c \times S_{x_p} = 1639.158 \times \text{ft} \times \text{kip}$

Moment capacity in tension  $M_{ct_p} := \phi_b \times f_t \times S_{x_p} = 193.21 \times \text{ft} \times \text{kip}$

check moment capacity

$\text{check } M_{c_p} := \begin{cases} \text{"Satisfactory"} & \text{if } \min(M_{cc_p}, M_{ct_p})^3 \geq M_{u_p}^3 \\ \text{"No good"} & \text{otherwise} \end{cases}$



**Check Shear and Maximum Moment in Pipes - Unusual Condition**

Depth from top of dike to water level,  $dw_{un} := 10.2\text{ft}$  (top of dike at EL 490.5', flood pool at EL 480.3')

Load due to water,  $W_{D_{un}} := \gamma_w \times OD_p \times (H_{emb} - dw_{un}) = 4.579 \times \frac{\text{kip}}{\text{ft}}$

Force from water,  $F_{D_{p_{un}}} := W_{D_{un}} \times L_e = 4.579 \times \text{kip}$

Moment load due to earth pressure,  $M_{O_{Fwe}} = 2.696 \times \text{ft} \times \text{kip}$

Moment load due to water,  $M_{O_{Fdp_{un}}} := \frac{W_{D_{un}} \times L_e^2}{8} = 0.572 \times \text{ft} \times \text{kip}$

Define load and resistance factors based on ACI 350 (conservatively use plain concrete values)

shear reduction factor  $\phi_c = 0.55$  ; bending moment reduction factor  $\phi_b = 0.55$

Maximum factored shear load  $V_{u_{p_{un}}} := \max(1.4 \times F_{D_{p_{un}}}, 1.2 \times F_{D_{p_{un}}} + 1.6 \times F_{W_e}) = 40.005 \times \text{kip}$

Shear capacity of pipe  $V_{c_p} = 160.206 \times \text{kip}$

check shear capacity  $\text{check}V_{c_{p_{un}}} := \begin{cases} \text{"Satisfactory"} & \text{if } V_{c_p} \geq V_{u_{p_{un}}} \\ \text{"No good"} & \text{otherwise} \end{cases} = \text{"Satisfactory"}$

Maximum factored moment load

$M_{u_{p_{un}}} := \max(1.4 \times M_{O_{Fdp_{un}}}, 1.2 \times M_{O_{Fdp_{un}}} + 1.6 \times M_{O_{Fwe}}) = 5.001 \times \text{ft} \times \text{kip}$

Moment capacity in compression  $M_{cc_p} = 1639.158 \times \text{ft} \times \text{kip}$

Moment capacity in tension  $M_{ct_p} = 193.21 \times \text{ft} \times \text{kip}$

check moment capacity

$\text{check}M_{c_{p_{un}}} := \begin{cases} \text{"Satisfactory"} & \text{if } \min(M_{cc_p}, M_{ct_p}) \geq M_{u_{p_{un}}} \\ \text{"No good"} & \text{otherwise} \end{cases} = \text{"Satisfactory"}$

### **36-inch RCP Northeast corner of Bottom Ash Pond to Middle Pond A**

#### **Check Shear and Maximum Moment in Pipes - Usual Condition**

Inner diameter of pipe,  $ID_p := 36\text{in}$       Wall thickness of pipe,  $t_{wp} := 4.75\text{in}$

Outer diameter of pipe,  $OD_p := ID_p + 2 \times t_{wp} = 45.5\text{in}$       Area of pipe,  $A_p := \frac{\pi}{4} \times (OD_p^2 - ID_p^2) = 4.223\text{ft}^2$

Unit weight of dike embankment,  $\gamma_{emb} := 120\text{pcf}$       Height of dike embankment,  $H_{emb} := 25\text{ft}$

Depth from top of dike to water level,  $dw := 4.5\text{ft}$  (top of dike at EL 482.5', normal pool at EL 478')

Vertical arching factor,  $VAF := 1.45$       Effective length of pipe,  $L_e := 1\text{ft}$

Load due to earth pressure,  $W_e := VAF \times \gamma_{emb} \times OD_p \times H_{emb} = 16.494 \times \frac{\text{kip}}{\text{ft}}$

Force from earth pressure,  $F_{W_e} := W_e \times L_e = 16.494 \times \text{kip}$

Load due to water,  $W_D := \gamma_w \times OD_p \times (H_{emb} - dw) = 4.85 \times \frac{\text{kip}}{\text{ft}}$

Force from water,  $F_{D_p} := W_D \times L_e = 4.85 \times \text{kip}$

Moment load due to earth pressure,  $M_{o\_Fwe} := \frac{W_e \times L_e^2}{8} = 2.062 \times \text{ft} \times \text{kip}$

Moment load due to water,  $M_{o\_Fdp} := \frac{W_D \times L_e^2}{8} = 0.606 \times \text{ft} \times \text{kip}$

Define load and resistance factors based on ACI 350 (conservatively use plain concrete values)  
 shear reduction factor  $\phi_c := 0.55$ ; bending moment reduction factor  $\phi_b := 0.55$

Maximum factored shear load       $V_{u_p} := \max(1.4 \times F_{D_p}, 1.2 \times F_{D_p} + 1.6 \times F_{W_e}) = 32.21 \times \text{kip}$

Shear capacity of pipe       $V_{c_p} := \phi_c \times 0.10 \times A_p = 100.336 \times \text{kip}$

check shear capacity       $\text{check}V_{c_p} := \begin{cases} \text{"Satisfactory"} & \text{if } V_{c_p} \geq V_{u_p} \\ \text{"No good"} & \text{otherwise} \end{cases}$

Maximum factored moment load       $M_{u_p} := \max(1.4 \times M_{o\_Fdp}, 1.2 \times M_{o\_Fdp} + 1.6 \times M_{o\_Fwe}) = 4.026 \times \text{ft} \times \text{kip}$

Section modulus of riser       $S_{x_p} := \frac{\frac{\pi}{64} \times (OD_p^4 - ID_p^4)}{\frac{OD_p}{2}} = 3.254 \times \text{ft}^3$

Moment capacity in compression  $M_{cc_p} := \phi_b \times f_c \times S_{x_p} = 773.248 \times \text{ft} \times \text{kip}$

Moment capacity in tension       $M_{ct_p} := \phi_b \times f_t \times S_{x_p} = 91.144 \times \text{ft} \times \text{kip}$

check moment capacity       $\text{check}M_{c_p} := \begin{cases} \text{"Satisfactory"} & \text{if } \min(M_{cc_p}, M_{ct_p}) \geq M_{u_p} \\ \text{"No good"} & \text{otherwise} \end{cases}$

**Check Shear and Maximum Moment in Pipes - Unusual Condition**

Depth from top of dike to water level,  $dw_{un} := 2.2$ ft (top of dike at EL 482.5', flood pool at EL 480.3')

Load due to water,  $W_{D_{un}} := \gamma_w \times OD_p \times (H_{emb} - dw_{un}) = 5.394 \times \frac{\text{kip}}{\text{ft}}$

Force from water,  $F_{D_{p_{un}}} := W_{D_{un}} \times L_e = 5.394 \times \text{kip}$

Moment load due to earth pressure,  $M_{o_{Fwe}} = 2.062 \times \text{ft} \times \text{kip}$

Momend load due to water,  $M_{o_{Fdp_{un}}} := \frac{W_{D_{un}} \times L_e^2}{8} = 0.674 \times \text{ft} \times \text{kip}$

Define load and resistance factors based on ACI 350 (conservatively use plain concrete values)

shear reduction factor  $\phi_c = 0.55$  ; bending moment reduction factor  $\phi_b = 0.55$

Maximum factored shear load  $V_{u_{p_{un}}} := \max(1.4 \times F_{D_{p_{un}}}, 1.2 \times F_{D_{p_{un}}} + 1.6 \times W_{e}) = 32.863 \times \text{kip}$

Shear capacity of pipe  $V_{c_{p}} = 100.336 \times \text{kip}$

check shear capacity  $\text{check} V_{c_{p_{un}}} := \begin{cases} \text{"Satisfactory"} & \text{if } V_{c_{p}} \geq V_{u_{p_{un}}} \\ \text{"No good"} & \text{otherwise} \end{cases} = \text{"Satisfactory"}$

Maximum factored moment load

$M_{u_{p_{un}}} := \max(1.4 \times M_{o_{Fdp_{un}}}, 1.2 \times M_{o_{Fdp_{un}}} + 1.6 \times M_{o_{Fwe}}) = 4.108 \times \text{ft} \times \text{kip}$

Moment capacity in compression  $M_{cc_{p}} = 773.248 \times \text{ft} \times \text{kip}$

Moment capacity in tension  $M_{ct_{p}} = 91.144 \times \text{ft} \times \text{kip}$

check moment capacity

$\text{check} M_{c_{p_{un}}} := \begin{cases} \text{"Satisfactory"} & \text{if } \min(M_{cc_{p}}, M_{ct_{p}}) \geq M_{u_{p_{un}}} \\ \text{"No good"} & \text{otherwise} \end{cases} = \text{"Satisfactory"}$

**48-inch RCP Southeast corner of Middle Pond A to Middle Pond A**

**Check Shear and Maximum Moment in Pipes - Usual Condition**

Inner diameter of pipe,  $ID_p := 48\text{in}$       Wall thickness of pipe,  $t_{wp} := 5.75\text{in}$   
 Outer diameter of pipe,  $OD_p := ID_p + 2t_{wp} = 59.5\text{in}$       Area of pipe,  $A_p := \frac{\pi}{4} \times OD_p^2 - ID_p^2 = 6.743\text{ft}^2$   
 Unit weight of dike embankment,  $\gamma_{emb} := 120\text{pcf}$       Height of dike embankment,  $H_{emb} := 25\text{ft}$   
 Depth from top of dike to water level,  $dw := 21.7\text{ft}$  (top of dike at EL 490', normal pool at EL 468.3')  
 Vertical arching factor,  $VAF := 1.45$       Effective length of pipe,  $L_e := 1\text{ft}$

Load due to earth pressure,  $W_e := VAF \times \gamma_{emb} \times OD_p \times H_{emb} = 21.569 \times \frac{\text{kip}}{\text{ft}}$

Force from earth pressure,  $F_{W_e} := W_e \times L_e = 21.569 \times \text{kip}$

Load due to water,  $W_D := \gamma_w \times OD_p \times (H_{emb} - dw) = 1.021 \times \frac{\text{kip}}{\text{ft}}$

Force from water,  $F_{D_p} := W_D \times L_e = 1.021 \times \text{kip}$

Moment load due to earth pressure,  $M_{O\_Fwe} := \frac{W_e \times L_e^2}{8} = 2.696 \times \text{ft} \times \text{kip}$

Moment load due to water,  $M_{O\_Fdp} := \frac{W_D \times L_e^2}{8} = 0.128 \times \text{ft} \times \text{kip}$

Define load and resistance factors based on ACI 350 (conservatively use plain concrete values)  
 shear reduction factor  $\phi_c := 0.55$ ; bending moment reduction factor  $\phi_b := 0.55$

Maximum factored shear load  $V_{u_p} := \max(1.4 \times F_{D_p}, 1.2 \times F_{D_p} + 1.6 \times F_{W_e}) = 35.735 \times \text{kip}$

Shear capacity of pipe  $V_{c_p} := \phi_c \times 0.10 \times f_c \times A_p = 160.206 \times \text{kip}$

check shear capacity  $\text{check} V_{c_p} := \begin{cases} \text{"Satisfactory"} & \text{if } V_{c_p} \geq V_{u_p} \\ \text{"No good"} & \text{otherwise} \end{cases} = \text{"Satisfactory"}$

Maximum factored moment load  $M_{u_p} := \max(1.4 \times M_{O\_Fdp}, 1.2 \times M_{O\_Fdp} + 1.6 \times M_{O\_Fwe}) = 4.467 \times \text{ft} \times \text{kip}$

Section modulus of riser  $S_{x_p} := \frac{\frac{\pi}{64} \times OD_p^4 - ID_p^4}{\frac{OD_p}{2}} = 6.899 \times \text{ft}^3$

Moment capacity in compression  $M_{cc_p} := \phi_b \times f_c \times S_{x_p} = 1639.158 \times \text{ft} \times \text{kip}$

Moment capacity in tension  $M_{ct_p} := \phi_b \times f_t \times S_{x_p} = 193.21 \times \text{ft} \times \text{kip}$

check moment capacity

$\text{check} M_{c_p} := \begin{cases} \text{"Satisfactory"} & \text{if } \min(M_{cc_p}, M_{ct_p}) \geq M_{u_p} \\ \text{"No good"} & \text{otherwise} \end{cases} = \text{"Satisfactory"}$



**Check Shear and Maximum Moment in Pipes - Unusual Condition**

Depth from top of dike to water level,  $dw_{un} := 10.4\text{ft}$  (top of dike at EL 490', flood pool at EL 479.6')

Load due to water,  $W_{D_{un}} := \gamma_w \times OD_p \times (H_{emb} - dw_{un}) = 4.517 \times \frac{\text{kip}}{\text{ft}}$

Force from water,  $F_{D_{p_{un}}} := W_{D_{un}} \times L_e = 4.517 \times \text{kip}$

Moment load due to earth pressure,  $M_{O_{Fwe}} = 2.696 \times \text{ft} \times \text{kip}$

Momend load due to water,  $M_{O_{Fdp_{un}}} := \frac{W_{D_{un}} \times L_e^2}{8} = 0.565 \times \text{ft} \times \text{kip}$

Define load and resistance factors based on ACI 350 (conservatively use plain concrete values)

shear reduction factor  $\phi_c = 0.55$  ; bending moment reduction factor  $\phi_b = 0.55$

Maximum factored shear load  $V_{u_{p_{un}}} := \max(1.4 \times F_{D_{p_{un}}}, 1.2 \times F_{D_{p_{un}}} + 1.6 \times F_{W_e}) = 39.931 \times \text{kip}$

Shear capacity of pipe  $V_{c_{p}} = 160.206 \times \text{kip}$

check shear capacity  $\text{check}V_{c_{p_{un}}} := \begin{cases} \text{"Satisfactory"} & \text{if } V_{c_{p}} \geq V_{u_{p_{un}}} \\ \text{"No good"} & \text{otherwise} \end{cases} = \text{"Satisfactory"}$

Maximum factored moment load

$M_{u_{p_{un}}} := \max(1.4 \times M_{O_{Fdp_{un}}}, 1.2 \times M_{O_{Fdp_{un}}} + 1.6 \times M_{O_{Fwe}}) = 4.991 \times \text{ft} \times \text{kip}$

Moment capacity in compression  $M_{cc_{p}} = 1639.158 \times \text{ft} \times \text{kip}$

Moment capacity in tension  $M_{ct_{p}} = 193.21 \times \text{ft} \times \text{kip}$

check moment capacity

$\text{check}M_{c_{p_{un}}} := \begin{cases} \text{"Satisfactory"} & \text{if } \min(M_{cc_{p}}, M_{ct_{p}}) \geq M_{u_{p_{un}}} \\ \text{"No good"} & \text{otherwise} \end{cases} = \text{"Satisfactory"}$

**48-inch HDPE from Middle Pond A to Ash Pond A**

Pipe buckling was analyzed as part of the CCR Rule demonstration. Buckling is caused by excessive vertical loading applied to the pipe through cover and surcharge loads. The buckling analysis was performed for the existing 48-inch outer diameter HDPE pipe. Drawing 10W263-02 specifies the pipe to be in accordance with TDOT specifications. TDOT references AWWA M55 - PE Pipe - Design and Installation for the HDPE pipes.

Apparent modulus of elasticity	$E_{\text{pipe}} := 28250\text{psi}$ (AWWA M55, Table 5-6, long term)
HDPE outside diameter	$OD := 48\text{in}$
HDPE wall thickness	$t_{\text{pipe}} := 3.556\text{in}$
HDPE inside diameter	$ID := OD - 2t_{\text{pipe}} = 40.888\text{in}$
Dimension ratio	$DR := \frac{OD}{t_{\text{pipe}}} = 13.498$
Dike crest elevation	$EL_{\text{crest}} := 479.5\text{ft}$
Normal pool elevation	$EL_{\text{np}} := 468.3\text{ft}$
Flood pool elevation	$EL_{\text{fp}} := 473\text{ft}$
Pipe invert elevation	$EL_{\text{in}} := 471.4\text{ft}$
Height of maximum soil cover	$H_{\text{cover}} := EL_{\text{crest}} - (EL_{\text{in}} + OD - t_{\text{pipe}}) = 4.396\text{ft}$
Height of soil above normal pool	$H_{\text{soil\_np}} := \min(H_{\text{cover}}, EL_{\text{crest}} - EL_{\text{np}}) = 4.396\text{ft}$
Height of soil submerged, normal pool	$H_{\text{submerged\_np}} := H_{\text{cover}} - H_{\text{soil\_np}} = 0\text{ft}$
Height of soil above flood pool	$H_{\text{soil\_fp}} := \min(H_{\text{cover}}, EL_{\text{crest}} - EL_{\text{fp}}) = 4.396\text{ft}$
Height of soil submerged, flood pool	$H_{\text{submerged\_fp}} := H_{\text{cover}} - H_{\text{soil\_fp}} = 0\text{ft}$
Modulus of soil reaction	$E' := 1300\text{psi}$ (Fine-grained soils relative compaction 90%, AWWA Table 6-1)
Safety factor for design	$FS_{\text{PE}} := 2$



**Allowable Buckling - normal pool**

Buoyancy factor  $R_{b\_np} := 1 - 0.33 \times \frac{H_{submerged\_np}}{H_{cover}} = 1$

Soil elastic support factor  $B' := \frac{1}{1 + 4 \times \frac{-0.065}{ft} \times H_{cover}} = 0.25$

Allowable external pressure for constrained pipe - buckling

$$P_{CA\_np} := \frac{5.65}{FS_{PE}} \times \sqrt{R_{b\_np} \times B' \times E \times \frac{E_{pipe}}{12 \times (DR - 1)^3}} = 55.884 \text{ psi}$$

**Allowable Buckling - flood pool**

Buoyancy factor  $R_{b\_fp} := 1 - 0.33 \times \frac{H_{submerged\_fp}}{H_{cover}} = 1$

Allowable external pressure for constrained pipe - buckling

$$P_{CA\_fp} := \frac{5.65}{FS_{PE}} \times \sqrt{R_{b\_fp} \times B' \times E \times \frac{E_{pipe}}{12 \times (DR - 1)^3}} = 55.884 \text{ psi}$$

**Calculate Applied Loads**

Dead load - usual condition

$$DL_u := \hat{e} \times \gamma_s \times H_{soil\_np} + (\gamma_s - \gamma_w) \times H_{submerged\_np} \times R_{b\_np} + \gamma_w \times H_{submerged\_np} = 3.206 \text{ psi}$$

Dead load - unusual condition

$$DL_{un} := \hat{e} \times \gamma_s \times H_{soil\_fp} + (\gamma_s - \gamma_w) \times H_{submerged\_fp} \times R_{b\_fp} + \gamma_w \times H_{submerged\_fp} = 3.206 \text{ psi}$$

Live load for AASHTO H20 loading under unpaved roads (AWWA M55, Table 5-3)

1.5	13.9
2.0	9.5
2.5	7.0
3.0	5.4
cover := 3.5	live <sub>load</sub> := 4.3
4.0	3.6
6.0	2.0
8.0	1.3
10.0	0.8

Exponential curve fit

$$e_{fit} := \expfit\left(\frac{cover}{ft}, \frac{live_{load}}{psi}\right) = 36.548 e^{-0.72x} + 1.203$$

$$aa := e_{fit}_0 = 36.548 \quad bb := e_{fit}_1 = -0.720 \quad cc := e_{fit}_2 = 1.203$$

$$f(x) := aa e^{bbx} + cc = 36.548373145638216 e^{-0.71974758459671384x} + 1.2033362039448283$$

Plot height of cover versus load for unpaved roads

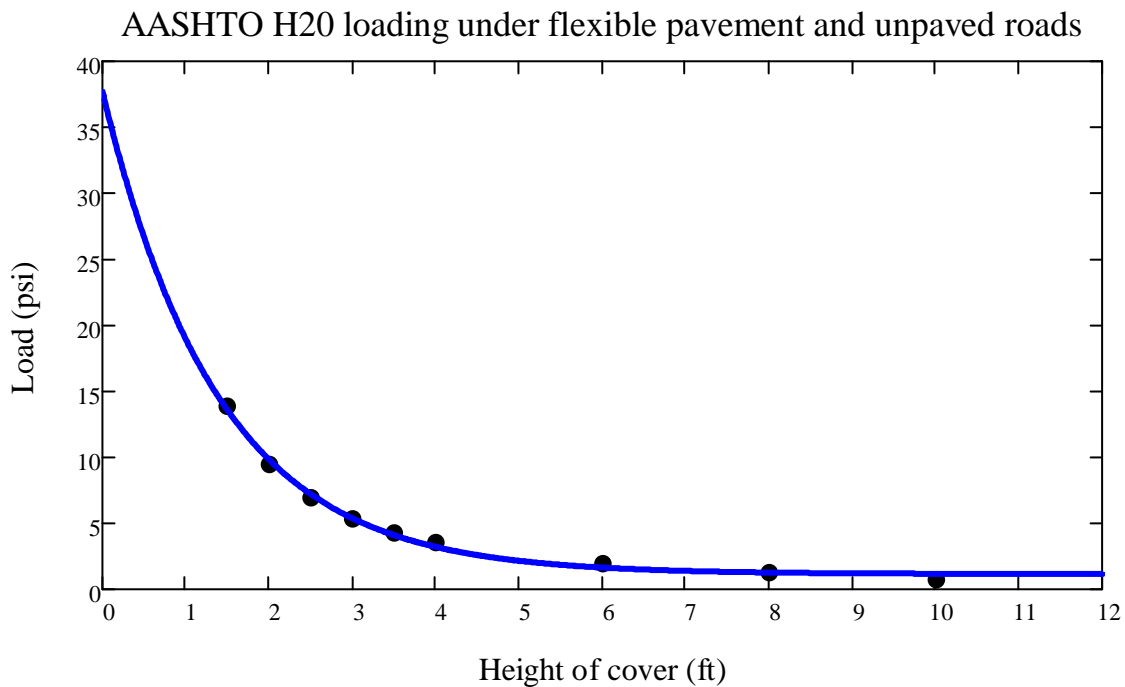

Live load on pipe  $LL := f_c \frac{a h_{cover}}{e \cdot ft \cdot \emptyset} \times psi = 2.747 \text{ psi}$

Total load - usual condition  $TL_u := DL_u + LL = 5.953 \text{ psi}$

Total load - unusual condition  $TL_{un} := DL_{un} + LL = 5.953 \text{ psi}$

Check critical buckling pressure - usual loading condition

$$check_{P_{cr\_u}} := \begin{cases} \text{"Satisfactory"} & \text{if } P_{CA\_np}^3 \cdot TL_u = \text{"Satisfactory"} \\ \text{"No good"} & \text{otherwise} \end{cases}$$

Check critical buckling pressure - unusual loading condition

$$check_{P_{cr\_un}} := \begin{cases} \text{"Satisfactory"} & \text{if } P_{CA\_fp}^3 \cdot TL_{un} = \text{"Satisfactory"} \\ \text{"No good"} & \text{otherwise} \end{cases}$$