



Stantec Consulting Services Inc.
9200 Shelbyville Road, Suite 800, Louisville, Kentucky 40222-5112

April 13, 2023
File: let_014_175578372
Revision 0

Tennessee Valley Authority
1101 Market Street
Chattanooga, Tennessee 37402

**RE: Periodic Structural Stability Assessment
 Fly Ash Stilling Pond 2C and Sluice Channel
 EPA CCR Rule
 TVA Bull Run Fossil Plant
 Clinton, Tennessee**

1.0 PURPOSE

This letter documents certification of the structural stability assessment in accordance with 40 CFR 257.73(d) of the EPA CCR Rule for the Fly Ash Stilling Pond 2C and Sluice Channel at the TVA Bull Run Fossil (BRF) Plant. The EPA CCR Rule requires periodic structural stability assessments, certified by a qualified professional engineer, every five years. The initial certification of structural stability was placed in the operating record on April 17, 2018.

2.0 INITIAL STRUCTURAL STABILITY ASSESSMENT

The initial structural stability assessment is attached. The results of the initial assessment found that the Fly Ash Stilling Pond 2C and Sluice Channel met the requirements of 40 CFR 257.73(d).

3.0 CURRENT STRUCTURAL STABILITY ASSESSMENT

Stantec reviewed the result of the initial structural stability assessment and the changes in the site conditions that have occurred in the past five years. Stantec also visually observed current site conditions during a site reconnaissance held on December 21, 2022. The following operational changes and other factors were considered in this periodic assessment:

1. Fly Ash Stilling Pond 2C is adjacent to the Main Ash Pond within the southwest portion of the BRF Plant property. The unit was closed in June 2020. CCR was removed and the area was repurposed to serve as a stormwater and non-CCR process water pond (Process Water Basin). Repurposing operations included, in part, removal of CCR, regrading the interior slopes of the perimeter dikes and installing a crushed stone drainage layer, geosynthetic liner, and riprap.
2. The Sluice Channel was closed and capped with a geomembrane liner system and a vegetative cover in 2017.
3. Non-CCR process water from the plant is conveyed to the Process Water Basin. The lined Process Water Basin was constructed within the repurposed footprint of the closed Fly Ash Stilling Pond 2C.



April 13, 2023

Page 2 of 3

Re: **Periodic Structural Stability Assessment
Fly Ash Stilling Pond 2C and Sluice Channel
EPA CCR Rule
TVA Bull Run Fossil Plant
Clinton, Tennessee**

4. Cross-sectional geometry of the exterior slope of the perimeter dike system has not changed.
5. The 100-year flood elevation of the Bull Run Creek (Melton Hill Lake) at the site has not changed.
6. The risers for the historic outlet structure at Outfall 001 have been removed, and the 36-inch diameter reinforced concrete outlet pipes were grouted and abandoned. The historic outlet structure was replaced with a 3-bay concrete stop log structure at Outfall 001.
7. An emergency spillway was constructed near the existing Outfall 001 along the west dike.
8. The concrete weir structure between the Main Ash Pond and Fly Ash Stilling Pond 2C (now closed) was removed. A new structure, which consists of a 3-bay concrete stop log structure, was constructed as part of the Process Water Basin project.
9. Annual inspection reports, conducted since 2018, were reviewed as part of this assessment. Nothing was identified that warranted remediation of any structural stability issues.
10. The perimeter dike and spillway structures were visually inspected during the site reconnaissance and no deficiencies that would negatively affect the structural stability assessment were observed.

Based on our review, there are no conditions that have changed in the past five years that would cause the result of the initial structural stability assessment to have changed.

4.0 SUMMARY OF ASSESSMENT

Based on review of the initial structural stability assessment and the items listed in Section 3.0, the result of this periodic structural stability assessment is that the Fly Ash Stilling Pond 2C and Sluice Channel at Bull Run Fossil Plant meets the requirements of §257.73(d) of the EPA CCR Final Rule.



April 13, 2023

Page 3 of 3

Re: **Periodic Structural Stability Assessment
Fly Ash Stilling Pond 2C and Sluice Channel
EPA CCR Rule
TVA Bull Run Fossil Plant
Clinton, Tennessee**

5.0 QUALIFIED PROFESSIONAL ENGINEER CERTIFICATION

I, Stephen H. Bickel, being a Professional Engineer in good standing in the State of Tennessee, do hereby certify, to the best of my knowledge, information, and belief:

1. that the information contained in this certification is prepared in accordance with the accepted practice of engineering;
2. that the information contained herein is accurate as of the date of my signature below; and
3. that this periodic structural stability assessment for the TVA Bull Run Fossil Plant Fly Ash Stilling Pond 2C and Sluice Channel meets the requirements specified in 40 CFR 257.73(d)(1) & (2).

SIGNATURE

Stephen H. Bickel

DATE

04/13/2023

ADDRESS:

Stantec Consulting Services Inc.
9200 Shelbyville Road, Suite 800
Louisville, Kentucky 40222-5212

TELEPHONE:

(502) 212-5075

ATTACHMENTS:

Initial Structural Stability Assessment



**INITIAL STRUCTURAL STABILITY
ASSESSMENT**



AECOM
1300 E. 9th Street, Suite 500,
Cleveland, OH 44114
www.aecom.com
216-622-2300 tel
216-622-2301 fax

April 13, 2018

Tennessee Valley Authority
1101 Market Street
Chattanooga, Tennessee 37402

**Initial Structural Stability Assessment
Stilling Pond 2C and Sluice Channel
EPA Final CCR Rule
TVA Bull Run Fossil Plant
Clinton, Tennessee**

1.0 PURPOSE

This letter documents AECOM's certification of the initial structural stability assessment for the TVA Bull Run Fossil Plant's Stilling Pond 2C and Sluice Channel. Based on this assessment, the Stilling Pond 2C and Sluice Channel is in compliance with the structural stability requirements in the Final CCR Rule at 40 CFR 257.73(d).

2.0 INITIAL STRUCTURAL STABILITY ASSESSMENT

As described in 40 CFR 257.73(d), documentation is required on how the Stilling Pond 2C and Sluice Channel has been designed, constructed, operated, and maintained according to the structural stability requirements listed in the section. This assessment considered the current conditions and construction within the limits of the Stilling Pond 2C and Sluice Channel.

3.0 SUMMARY OF FINDINGS

The attached report presents the initial structural stability assessment of the Stilling Pond 2C and Sluice Channel. The results show that the Stilling Pond 2C and Sluice Channel meet the structural stability requirements set forth in 40 CFR 257.73(d)(1)-(2).

Remainder of Page Left Blank Intentionally



AECOM
1300 E. 9th Street, Suite 500,
Cleveland, OH 44114
www.aecom.com
216-622-2300 tel
216-622-2301 fax

4.0 QUALIFIED PROFESSIONAL ENGINEER CERTIFICATION

I, Thomas Kovacic, being a Professional Engineer in good standing in the State of Tennessee, do hereby certify, to the best of my knowledge, information, and belief:

1. that the information contained in this certification is prepared in accordance with the accepted practice of engineering;
2. that the information contained herein is accurate as of the date of my signature below; and
3. that the initial structural stability assessment for the TVA Bull Run Fossil Plant's Stilling Pond 2C and Sluice Channel meet the requirements specified in 40 CFR 257.73(d)(1)-(2).

SIGNATURE _____

DATE 4-13-2018

ADDRESS: AECOM
1300 E. 9th Street
Suite 500
Cleveland, OH 44114

TELEPHONE: (216) 622-2300

ATTACHMENTS: Initial Structural Stability Assessment 40 CFR 257.73(d)(1); Existing CCR Surface Impoundments: TVA Bull Run Fossil Plant: Stilling Pond 2C and Sluice Channel

COAL COMBUSTION PRODUCT DISPOSAL PROGRAM

**Tennessee Valley Authority – Fly Ash Stilling Pond 2C, Sluice
Channel, Main Ash Pond
Sumner County, Tennessee**

**Initial Structural Stability Assessment
40 CFR 257.73(d)(1)
Existing CCR Surface Impoundments
TVA Bull Run Fossil Plant**

Prepared for



Tennessee Valley Authority
1101 Market Street
Chattanooga, TN 37402-2801

April 13, 2018

Prepared by

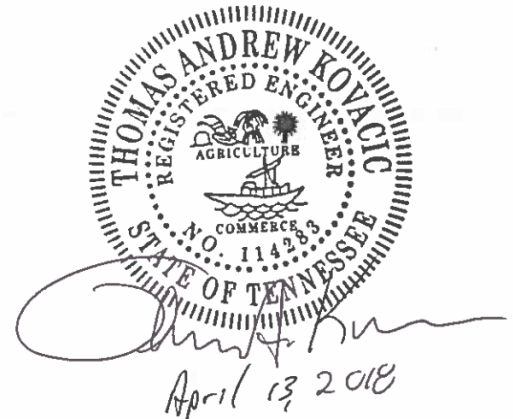



Table of Contents

1.0	Project Background	1
2.0	Structural Stability Assessment - §257.73(d)(1)	1
2.1	Foundations and Abutments - §257.73(d)(1)(i)	2
2.2	Slope Protection - §257.73(d)(ii)	3
2.3	Embankment Dike Compaction - §257.73(d)(1)(iii)	4
2.4	Vegetated Slopes - §257.73(d)(1)(iv)	4
2.5	Spillway Capacity - §257.73(d)(1)(v)	4
2.5.1	Spillway Capacity at Sustained Flows - §257.73(d)(1)(v)(A)	4
2.5.2	Spillway Capacity at Peak Discharge - §257.73(d)(1)(v)(B)	5
2.6	Hydraulic Structures - §257.73(d)(1)(vi)	5
2.6.1	Pipes	6
2.6.2	Spillway - Vertical Risers	6
2.7	Sudden Drawdown - §257.73(d)(1)(vii)	7
3.0	Conclusion	7
4.0	References	8

Figures

Figure 1: Ash Pond Complex

Appendices

Appendix A Hydraulic Structures Assessment Calculation Package

Appendix B Images

1.0 Project Background

On April 17, 2015 the “Disposal of Coal Combustion Residuals (CCR) from Electric Utilities” (CCR Rule) was published in the Federal Register. AECOM has been contracted by TVA to analyze the Structural Stability of the Bull Run Fossil (BRF) Plant’s CCR surface impoundments and evaluate compliance with §257.73 of the CCR Rule. Initially, the units at BRF were determined not to require analysis and compliance with the CCR Rule, but have now been determined to be pertinent to the CCR Rule.

As required by §257.100(e)(i) of the Final CCR Rule, an initial structural integrity evaluation was required by April 17, 2018 and must include an initial structural stability assessment for each inactive existing CCR surface impoundment that meets the conditions of paragraph (b) as follows:

1. Has a height of five feet or more and a storage volume of 20 acre-feet or more or
2. Has a height of 20 feet or more.

Fly Ash Stilling Pond 2C and Main Ash Pond meet both criteria. The Sluice Channel is in the process of closure and was an incised CCR unit, so the requirements in §257.73 do not apply. A plan view showing the location of Fly Ash Stilling Pond 2C, Sluice Channel, and Main Ash Pond is shown in **Figure 1**.



Figure 1: Ash Pond Complex

2.0 Structural Stability Assessment - §257.73(d)(1)

40 CFR 257.73(d)(1). Periodic structural stability assessments. (1) The owner or operator of the CCR unit must conduct initial and periodic structural stability assessments and document whether the design, construction, operation, and maintenance of the CCR unit is consistent

with recognized and generally accepted good engineering practices for the maximum volume of CCR and CCR wastewater which can be impounded therein. The assessment must, at a minimum, document whether the CCR unit has been designed, constructed, operated, and maintained with:

- (i) Stable foundations and abutments;*
- (ii) Adequate slope protection to protect against surface erosion, wave action, and adverse effects of sudden drawdown;*
- (iii) Dikes mechanically compacted to a density sufficient to withstand the range of loading conditions in the CCR unit;*
- (iv) Vegetated slopes of dikes and surrounding areas, except for slopes which have an alternate form or forms of slope protection;*
- (v) A single spillway or a combination of spillways configured as specified in paragraph (d)(1)(v)(A) of this section. The combined capacity of all spillways must be designed, constructed, operated, and maintained to adequately manage flow during and following the peak discharge from the event specified in paragraph (d)(1)(v)(B) of this section.*
- (vi) Hydraulic structures underlying the base of the CCR unit or passing through the dike of the CCR unit that maintain structural integrity and are free of significant deterioration, deformation, distortion, bedding deficiencies, sedimentation, and debris which may negatively affect the operation of the hydraulic structure; and*
- (vii) For CCR units with downstream slopes which can be inundated by the pool of an adjacent water body, such as a river, stream or lake, downstream slopes that maintain structural stability during low pool of the adjacent water body or sudden drawdown of the adjacent water body.*

2.1 Foundations and Abutments - §257.73(d)(1)(i)

The Bull Run Fossil Plant (BRF) is located within Anderson County in Clinton, TN. The Clinch River runs along the western side of the plant and Bull Run Creek, a tributary of the Clinch River, runs along the southern side of the plant. Accordingly, the majority of the ash pond complex is underlain by alluvial deposits consisting of silts and clays with varying amounts of sand. Other areas of the plant are underlain by residual soils resulting from in-place weathering of the parent Ordovician and Cambrian aged limestone and calcareous shale bedrock formations.

The foundation of the perimeter dikes of Fly Ash Stilling Pond 2C and Main Ash Pond typically consist of clay/sand deposits. The foundation of the divider dike between the ponds consists of sluiced ash. The clay deposits consist of light brown to red-brown, medium stiff to hard, fat clay (CH) that transitioned to medium stiff or soft lean clay (CL) with varying amounts of sand. The sand deposits consist of light brown to brown, very loose, medium to coarse grained, clayey sand (SC) and silty sand (SM). The sluiced ash classified as very loose to loose, silty poorly graded sand (SM, SP-SM).

The dike foundations were prepared to provide a stable area for dike embankment fill placement. The foundation area was cleared of trees, brush, stumps, and roots. Thereafter, soft materials not suitable for fill were excavated and removed, and the entire foundation area was compacted with a sheepfoot roller followed by a smooth drum roller.

A dam assessment and inspection of the Ash Pond Complex, which includes Fly Ash Stilling Pond 2C, Sluice Channel, and Main Ash Pond at BRF, was completed in 2011 and 2017, respectively (see references [8] and [15]). Based on the reports, no evidence of structural weakness of the inspected units was observed. No significant signs of tension cracking, settlement, depressions, erosion, and/or deformations at the crest, slope and toe of the dikes were observed. No boils or major uncontrollable seepage areas was observed along slopes or toes of the dikes. Finally, the stability of the slopes has been confirmed through TVA's Instrumentation Program (see reference [11]).

Also, an assessment of seepage for Stilling Pond 2C and Main Ash Pond including an evaluation of piping potential of the foundation material was performed, and the results of the assessment were provided in geotechnical evaluation reports dated July 2017 and April 2010, respectively (see reference [3] and [9]). Seepage analyses were performed at two cross sections across the Stilling Pond perimeter dike and two cross sections across the Main Ash Pond perimeter dike using Geoslope, Inc.'s SEEP/W software. As part of that analysis, horizontal and vertical gradients were determined near the toe of the downstream slope. A determination of critical, vertical exit gradients was performed following established sources (including Terzaghi and Peck, USACE EM 1110-2-1901, and USBR Design Standard No. 13 Embankment Dams). Seepage exit gradients determined from the seepage analysis were compared with the critical gradient to calculate a safety factor against piping. For the analyzed cross sections, the minimum computed safety factor against piping was recorded at 4.0.

Seepage conditions have been analyzed in accordance with acceptable methodologies. All seepage modeling performed indicated a factor of safety against piping of greater than 3, which exceeds the requirement of 3.0 stated in USACE EM 1110-2-1901. Based on existing analytical data and results, the existing embankments and foundation materials are performing acceptably in regard to piping and heave potential in comparison to current criteria. Further, no physical or visual evidence of piping, heave, or uplift has been observed during multiple visits to the site between 2016 and 2017.

2.2 Slope Protection - §257.73(d)(ii)

The slopes along the perimeter dikes are generally protected with either dense grass or riprap; no trees or large, bushy vegetation are present on the slopes.

No additional slope protection is required since there is adequate freeboard during the 1,000-year, 6-hour storm event (reported at 4.85-ft and 8.77-ft for Main Ash Pond and Stilling Pond 2C, respectively in the hydrology and hydraulics report; see reference [7]).

2.3 Embankment Dike Compaction - §257.73(d)(1)(iii)

Construction documents (see references [14]) indicate that the materials used to construct both the original perimeter dike and the raised dike for Fly Ash Stilling Pond 2C and Main Ash Pond were mechanically compacted. The perimeter dikes were designed to be constructed of fill materials from an approved earth borrow area. No muck, sod, roots, brush, construction debris, or other unsuitable materials were allowed to be included in the fill. The fill materials were to be spread in layers of loose thickness to achieve a compacted layer thickness of about 6 inches using a roller compactor. Surfaces where earthfill was to be placed were scarified to achieve bond between compacted layers.

Geotechnical investigations by Stantec (see reference [9]) of the perimeter dike encountered materials with standard penetration test (SPT) blow count values indicating compactive effort. During the inspection completed in March 2017, no instabilities, erosion, or depressions were found on the dike interior or exterior slopes. And no settlement/cracking, rutting, or lateral displacement of the dike crests were noted.

2.4 Vegetated Slopes - §257.73(d)(1)(iv)

The slopes of the dikes and divider dikes that form the Stilling Pond 2C and Main Ash Pond have been maintained with either dense grass or riprap; no trees or large, bushy vegetation are present on the slopes.

2.5 Spillway Capacity - §257.73(d)(1)(v)

Per §257.73(d)(1)(v),

(A) *All spillways must be either:*

- (1) *Of non-erodible construction and designed to carry sustained flows; or*
- (2) *Earth- or grass-lined and designed to carry short-term, infrequent flows at non-erosive velocities where sustained flows are not expected.*

(B) *The combined capacity of all spillways must adequately manage flow during and following the peak discharge from a:*

- (1) *Probable maximum flood (PMF) for a high hazard potential CCR surface impoundment; or*
- (2) *1000-year flood for a significant hazard potential CCR surface impoundment; or*
- (3) *100-year flood for a low hazard potential CCR surface impoundment.*

2.5.1 Spillway Capacity at Sustained Flows - §257.73(d)(1)(v)(A)

Main Ash Pond does not have any spillway features. Stilling Pond 2C uses three reinforced concrete pipe (RCP) spillway risers. During normal operating conditions, the RCP spillways are used to discharge sustained flows from Stilling Pond 2C to the Clinch River.

The spillways are constructed of reinforced concrete which is a non-erodible material that is resistant to the flow of water. According to the hydrologic and hydraulic (H&H) study completed in 2017 (see reference [7]), the spillway is adequate to carry the sustained flows.

2.5.2 Spillway Capacity at Peak Discharge - §257.73(d)(1)(v)(B)

Based on a hazard assessment (see reference [11]), Stilling Pond 2C has been classified as a significant hazard potential. Therefore, the combined capacity of all spillways in Stilling Pond 2C must adequately manage flow during and following the peak discharge from a 1000-year flood.

According to the Hydrology & Hydraulics study completed in 2017 (see reference [7]), the combined capacity of the spillways is adequate to manage the flow during and following the peak discharge from a 1000-year flood.

2.6 Hydraulic Structures - §257.73(d)(1)(vi)

Currently, a process water ditch (conveyance ditch) begins at a concrete inlet at the far upstream end. The conveyance ditch receives non-CCR process water from the plant. The conveyance ditch runs approximately 5,800 feet to the Main Ash Pond. The conveyance ditch also collects stormwater flows from the Bottom Ash Disposal Area, the Gypsum Disposal Area, and the closed Sluice Ditch. To pass flow underneath access roads, two sets of pipes were constructed as part of the conveyance ditch. A set of three 48-inch diameter HDPE culvert pipes were used to pass flow underneath the access road near the southeast corner of the Bottom Ash Disposal area. A set of four 48-inch diameter HDPE culvert pipes were used to pass flow underneath the access road within the northeast corner of the Main Ash Pond.

In addition to the flows carried by the conveyance ditch, the Main Ash Pond receives stormwater from direct rainfall and stormwater from the Gypsum Stack via two riser pipes with HDPE outlets into the north side of the Main Ash Pond.

The Stilling Pond 2C receives flow from the Main Ash Pond via a rock-lined channel, roughly 20-feet wide, with a concrete weir spanning the width of the channel that creates a surface water differential of about 0.5-feet. The Stilling Pond 2C also receives direct rainfall.

All of the flow is discharged through the existing spillways in Stilling Pond 2C. The spillways consist of three reinforced concrete riser structures fitted with a steel weir ring and skimmer at approximately elevation 800-feet. Each riser outlets into three separate 36-inch diameter reinforced concrete pipes that discharge into the Clinch River.

The hydraulic structures that have an impact on the structural integrity of the CCR units are the riser structures in the Stilling Pond 2C and their outlet pipes that run underneath the perimeter dike. Other hydraulic structures at BRF do not directly impact the structural integrity of the CCR units.

2.6.1 Pipes

The existing outlet pipes under the perimeter dike between Stilling Pond 2C and the Clinch River have been inspected via camera. The video inspection was completed prior to the spillway modification project completed in 2011. The interior of the outlet pipes were generally in good condition with some minor to moderate deposit encrustation (see **Appendix B** showing an image from the video inspection of the middle outlet pipe). Minimal joint leaking was also noted in the outlet pipes. Evaluation of the video recordings showed a clear pathway for the water flow without any significant obstruction or debris present inside the outlet pipes. Visual inspections of the dikes where pipes pass through do not show any signs of deformation. The pipes have been evaluated for buckling stability for two different limit states: usual loading conditions associated with regularly occurring pool levels and unusual loading conditions associated with the design flood event. All associated calculations, including the structure's geometry and material properties are included in **Appendix A**. The pipes satisfy the stability checks for the limit states considered. Also, in the Stilling Pond Closure Plan (AECOM drawing 10W524-09), the outlet pipes will be slip lined using cured-in-place (CIPP) lining. The liner will seal the pipe joints and add a layer of protection against leakage.

2.6.2 Spillway - Vertical Risers

The spillway consisting of three 48" RCP vertical risers is located at the northwest end of Stilling Pond 2C. The original construction drawings used to determine the dimension of the vertical risers and are referenced in **Appendix A**. The risers were all constructed similarly. Each riser is founded on a reinforced concrete pad (6.5ft wide x 6.5ft long x 1.5ft deep). A reinforced concrete junction box (6ft wide x 6ft long x 4ft tall) with 12" wall thickness is attached to the foundation. Two feet lengths of 48" diameter Class III RCP were stacked on the junction box to raise the risers to their current elevations. Construction documents state that pipe joints were to be grouted to form stable and water-tight connections. Each riser was covered with a skimmer composed of a 5-foot section of 120" diameter galvanized CMP with interior steel angle bracing. Water flows east to west via three 36" diameter RCPs that extend from the junction box of the risers under the perimeter dike and discharges into the Clinch River. The outlet pipes are approximately 118-feet long.

The spillways were modified in 2011 to lower the water level to an approximate elevation of 800 ft (see references [17]). The top three concrete pipe sections were removed from each spillway. The remaining concrete riser was encased in reinforced concrete which sealed the joint between the junction box and riser. The concrete jacket was attached to the existing box structure using rebar dowels. A stainless steel weir ring was added to the top of the modified spillways. The skimmer hoods rest on the weir ring. The spillways were stabilized by placing an 18" thick riprap layer around them.

During the site inspection on March of 2017 (see reference [15]), photographs were taken showing the condition of the spillway inlet. The spillway risers were accessed via an adjacent boardwalk. No deterioration was observed at the base of the CMP skimmers. Surface rusts were present on the CMP skimmers and associated steel bracings. There were no apparent

deteriorations or obstructions to water flow from the top of the risers. **Photo 9** in the inspection report shows the typical condition of the risers.

The riser structures were evaluated for two different limit states. The first limit state is associated with regularly occurring pool levels (usual loading conditions). The critical condition for floatation of the riser structures occurs when the pool level is near the top of the riser structures but does not flow over. It was assumed that the riser structures were not filled with water. The buoyant force was applied at the bottom of the foundation. The critical condition for bearing capacity occurs when the risers are filled with water. Sliding and overturning moment were not checked for this limit state because the structure is subjected to equalized hydrostatic pressure.

The second limit state is associated with loading under the 1000-year flood event (unusual loading conditions). Evaluation for this flood event is required for a structure defined to have a significant hazard potential per CCR Rule. It has been determined that the 1000-year flood event will not overtop the pond dikes, so there will be no stream flow against the side of the riser structures that will cause instability issues. For informational purposes, analyses were completed using the maximum water flow velocity for which the structural stability of the riser structures was satisfied.

The shear and maximum moment in the outlet pipes were also checked for both limit states described above. All associated calculations, including structure geometry and material properties are included in **Appendix A**. The risers and pipes satisfy all strength and stability checks for the limit states considered. Thus, no rehabilitation is required at this time.

2.7 Sudden Drawdown - §257.73(d)(1)(vii)

Fly Ash Stilling Pond 2C and Main Ash Pond will not experience the sudden drawdown condition because the 100-yr. floodplain of the Clinch River and Bull Run Creek does not inundate the perimeter dikes.

3.0 Conclusion

Based on the results of the initial structural stability assessment, Fly Ash Stilling Pond 2C and Main Ash Pond meet the requirements of the CCR Rule as discussed in **Section 2.0**.

4.0 References

- [1] AECOM, "Bull Run Fossil Plant, BRF Conveyance Ditch As-Built Drawings," April 2016.
- [2] AECOM, "BRF Fly Ash Pond Closure Plan Construction Drawings," January 2017.
- [3] AECOM, "Geotechnical Report, Stilling Pond Dike Evaluation, Bull Run Fossil Plant," July 2017.
- [4] AECOM, "Stilling Pond Lining and Repurposing Basis of Design Calculations," July 2017.
- [5] AECOM, "Bull Run Fossil Plant, Bull Run Stilling Pond Closure Plan Construction Drawings," August 2017.
- [6] AECOM, "Fly Ash Pond Closure Basis of Design Calculations," August 2017.
- [7] AECOM, "Hydrology & Hydraulics Report, Bull Run Fossil Plant," August 2017.
- [8] Dewberry Consultants LLC, "Coal Combustion Residue Impoundment, Round 11 - Dam Assessment Report," December 2012.
- [9] Stantec Consulting Services Inc., "Report of Geotechnical Exploration, Bottom Ash Disposal Area 1, Gypsum Disposal Area 2A, and Fly Ash Pond Area 2, Bull Run Fossil Plant," April 2010.
- [10] Stantec Consulting Services Inc., "Report of Breach Analysis for BRF Ash Pond Complex," April 2011.
- [11] Stantec and AECOM, "Annual Instrumentation and Monitoring Program Final Report (Rev. 2); Fiscal Year 2015; Tennessee Valley Authority Instrumentation Monitoring Program; Coal Combustion Product (CCP) Storage Facilities; Various Plants Alabama, Kentucky, and Tennessee.," February 2016.
- [12] Tennessee Valley Authority, "Standard Drawing 10N282 R1," April 1975.
- [13] Tennessee Valley Authority, "Standard Drawing 10N283 R0," April 1975.
- [14] Tennessee Valley Authority, "Construction Notes Drawing 10W294-05 R0," April 1988.
- [15] Tennessee Valley Authority, "2017 Annual (Intermediate) Inspection of CCR facilities at Bull Run Fossil (GAF) Plant," April 2017.
- [16] URS, "Seepage and Slope Stability Remediation Basis of Design," July 2011.
- [17] URS, "Bull Run Fossil Plant Outfall 001 Spillway Modifications Record Drawings," 2012.
- [18] USACE, "USACE EM 1110-2-1902 Slope Stability," October 2003.
- [19] USBR, "Design Standard No. 13: Embankment Dams," January 2014.

APPENDIX A
HYDRAULIC STRUCTURES ASSESSMENT
CALCULATION PACKAGE

**Initial Structural Stability Assessment
for Riser Structures in Stilling Pond 2C
at TVA Bull Run Fossil Plant**

Prepared for



Tennessee Valley Authority
1101 Market Street
Chattanooga, Tennessee 37402-2801

Prepared by



1000 Corporate Centre Drive, Suite 250
Franklin, Tennessee 37067-6209

Discussion

The following calculations detail the structural stability assessment for the existing riser structures in Stilling Pond 2C at Tennessee Valley Authority (TVA) Bull Run Fossil Plant (BRF). The calculations were completed in accordance with United States Environmental Protection Agency's (EPA) requirements under the Hazardous and Solid Waste Management System; Disposal of Coal Combustion Residuals (CCR) from Electric Utilities [RIN-250-AE81; FRL-9149-4] (EPA Final CCR Rule) section 257.73(d).

References

- 1.) TVA-CCR Rule Template 257.73 (d).
- 2.) Existing drawings listed under Riser and skimmer geometry.
- 3.) AECOM Geotechnical Report Stilling Pond Dike Evaluation Bull Run Fossil Plant, July 2017.
- 4.) USACE EM 1110-2-2100, Stability Analysis of Concrete Structures, December 2005.
- 5.) USACE EM 1110-1-1905, Bearing Capacity of Soils, October 1992.

Material Properties and Geometry

The material properties and geometry defined below are determined using TVA CCR rule template 257.73(d), existing project drawings, geotechnical data report, historical data, and engineering judgement.

Soil properties

Unit weight of water	$\gamma_w := 62.4 \text{pcf}$
Unit weight of foundation soil	$\gamma_s := 100 \text{pcf}$
Friction angle of foundation soil	$\phi_s := 26^\circ$
Cohesion of foundation soil	$c_s := 0 \text{psf}$

Concrete material properties

Reference TVA CCR Rule 257.73(d), 2.1.1

Unit weight of concrete	$\gamma_c := 150 \text{pcf}$
Poisson's ratio	$\nu_c := 0.2$
Unconfined compressive strength	$f_c := 3000 \text{psi}$ Class A concrete
Shear strength	$\tau_c := 0.10 \times f_c = 300 \text{psi}$
Static tensile strength	$f_t := 1.7 \text{psi} \times \frac{f_c^{0.5}}{\text{psi}^{0.5}} = 353.614 \text{psi}$
Dynamic tensile strength	$f_{td} := 1.5 \times f_t = 530.421 \text{psi}$
Instantaneous elastic modulus	$E_c := 57000 \times \sqrt{f_c} \text{psi} = 3122.019 \text{ksi}$
Sustained elastic modulus	$E_{cs} := 0.70 \times E_c = 2185.413 \text{ksi}$

Reinforcing steel material properties

Reference TVA CCR Rule 257.73(d), 2.1.1

Yield strength	$f_y := 60 \text{ksi}$
Elastic modulus	$E_s := 29000 \text{ksi}$



Riser and skimmer geometry

Reference:

- 1.) TVA, Ash Disposal Spillway Standard Drawing No. 10N282 dated APR-10-1975.
- 2.) TVA, Weir for Ash Disposal Spillway Standard Drawing No. 10N283 dated APR-10-1975.
- 3.) AECOM, Outfall 001 Spillway Details Drawing No. 10W281-11 dated AUG-3-2011.

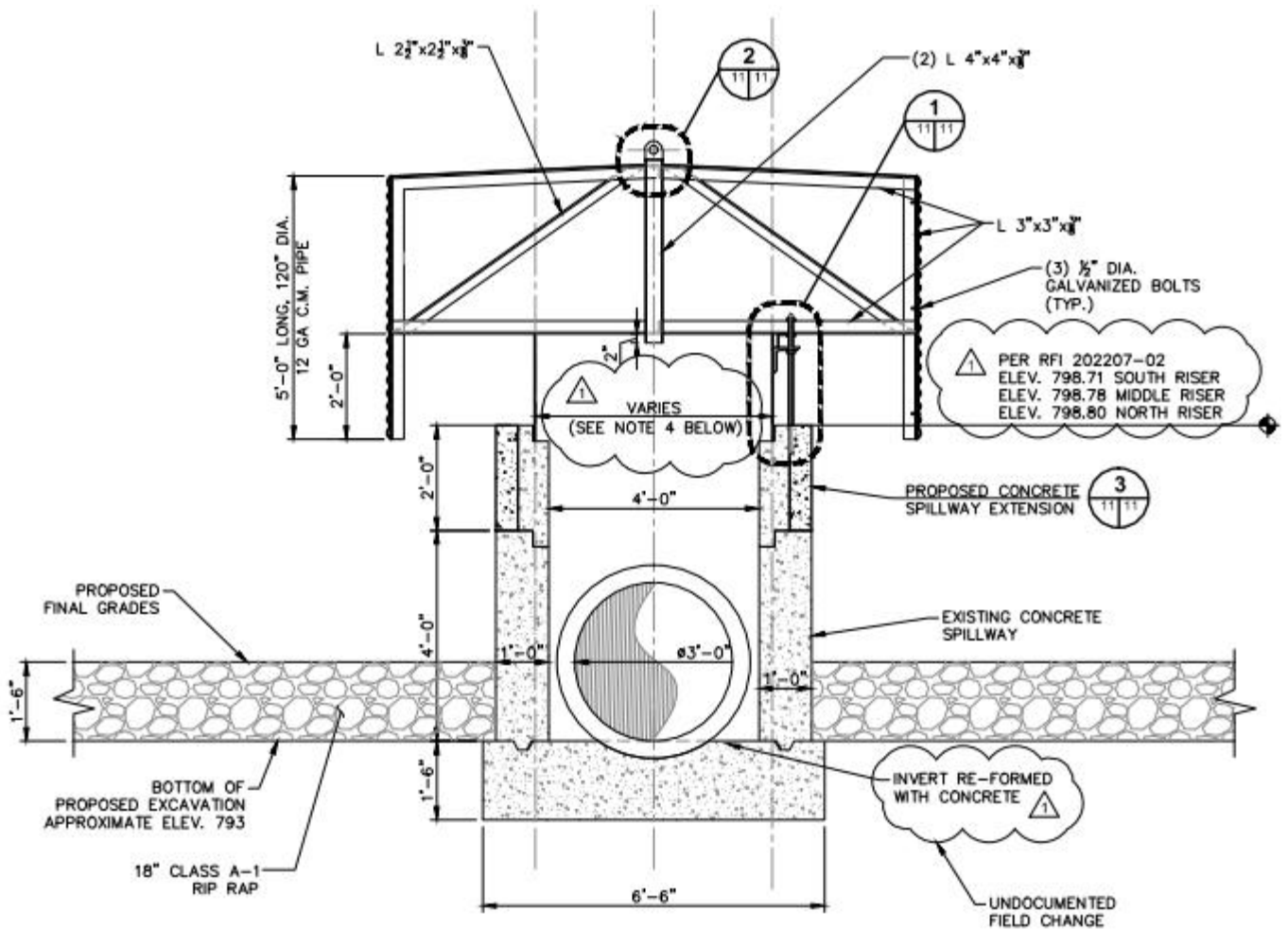

Figure 1: Spillway Section from 10W281-11

Riser geometry

Top elevation of riser structure	$EL_{top} := 798.8\text{ft}$ (not including weir/skimmer)
Bottom elevation (at top of foundation)	$EL_{bot} := 792.56\text{ft}$
Height of structure	$H_{structure} := EL_{top} - EL_{bot} = 6.24\text{ft}$
Height of water outside (from top of foundation)	$H_{wo} := H_{structure} + 2\text{ft} = 8.24\text{ft}$
Foundation - width of footing	$B_{ftg} := 6.5\text{ft}$
Foundation - length of footing	$L_{ftg} := 6.5\text{ft}$
Foundation - depth of footing	$D_{ftg} := 1.5\text{ft}$
Foundation - volume	$V_{ftg} := B_{ftg} \times L_{ftg} \times D_{ftg} = 63.375\text{ft}^3$
Foundation - weight	$W_{ftg} := V_{ftg} \times \gamma_c = 9.506\text{kip}$
Junction box - external width	$B_{box} := 6.0\text{ft}$
Junction box - wall thickness	$t_{box} := 1.0\text{ft}$
Junction box - height	$h_{box} := 4.0\text{ft}$
Junction box - volume	$V_{box} := \frac{\pi}{4} \times B_{box}^2 \times h_{box} - (B_{box} - 2 \times t_{box})^2 \times h_{box} = 80\text{ft}^3$
Junction box - weight	$W_{box} := V_{box} \times \gamma_c = 12\text{kip}$
Riser pipe - inner diameter	$ID_{rsr} := 4.0\text{ft}$
Riser pipe - thickness	$t_{rsr} := 4.0\text{in}$
Riser pipe - outer diameter	$OD_{rsr} := ID_{rsr} + 2 \times t_{rsr} = 4.667\text{ft}$
Riser pipe - total height	$h_{rsr} := 2\text{ft}$
Riser pipe - cross sectional area	$A_{rsr} := \frac{\pi}{4} \times OD_{rsr}^2 - ID_{rsr}^2 = 4.538\text{ft}^2$
Riser pipe surrounded with reinforced concrete	$A_{rsrc} := B_{box}^2 - \frac{\pi}{4} \times OD_{rsr}^2 = 18.896\text{ft}^2$
Riser pipe - volume	$V_{rsr} := (A_{rsr} + A_{rsrc}) \times h_{rsr} = 46.867\text{ft}^3$
Riser pipe - weight	$W_{rsr} := V_{rsr} \times \gamma_c = 7.03\text{kip}$

Skimmer geometry

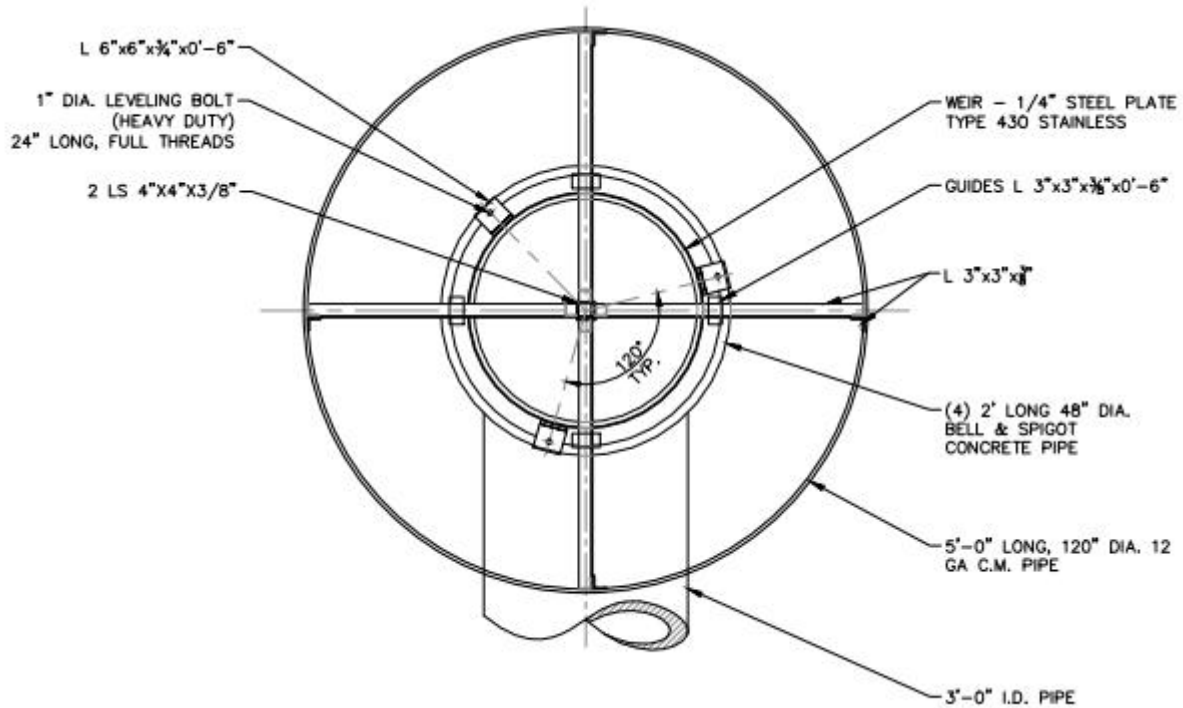

Figure 2: Top View of Skimmer from 10W281-11

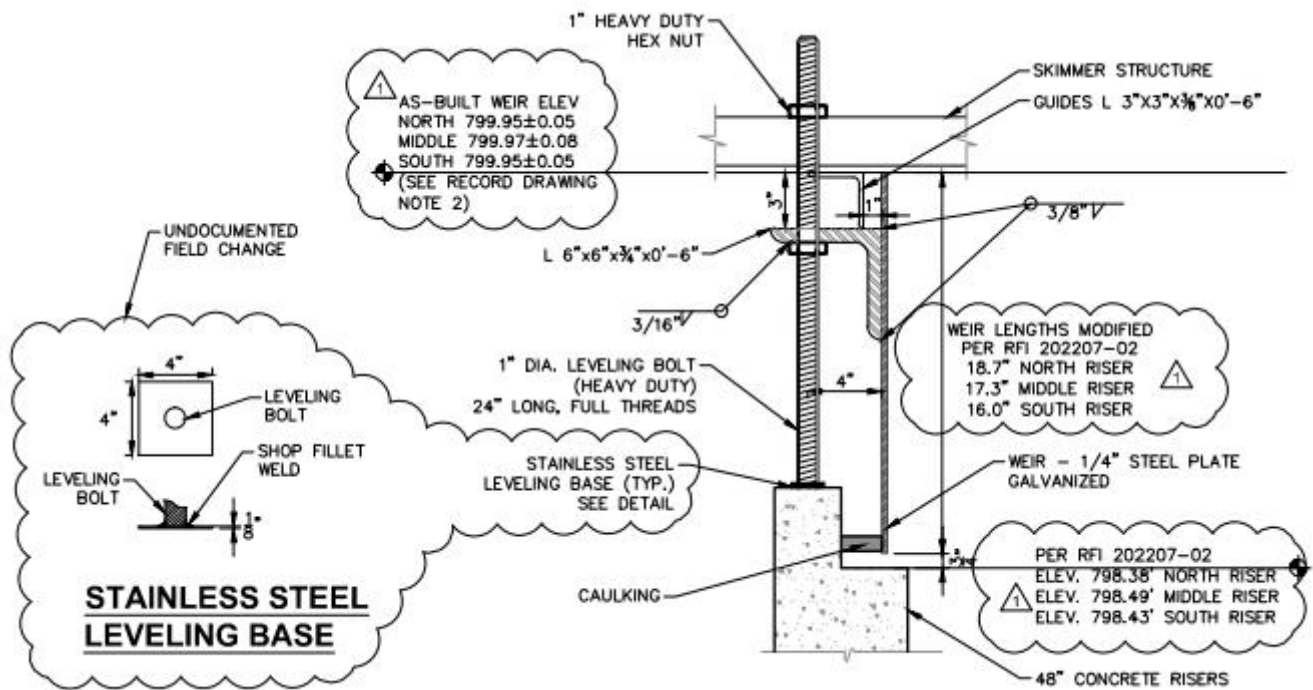

Figure 3: Weir Detail from 10W281-11

Weir ring - 1/4 in stainless steel plate, type 430

unit weight $\gamma_{ss} := 10\text{psf}$; height $h_{ss} := 1.4975\text{ft}$; length $l_{ss} := 13.679\text{ft}$; weight $W_{wr1} := \gamma_{ss} \times h_{ss} \times l_{ss} = 204.843\text{ lbf}$

Weir ring - three 1" diameter leveling bolts

quantity $q_b := 3$; unit weight $\gamma_b := 2.7\text{plf}$; length $l_{bolt} := 2\text{ft}$; weight $W_{wr2} := q_b \times \gamma_b \times l_{bolt} = 16.2\text{ lbf}$

Weir ring - three L6x6x3/4 angles

quantity $q_a := 3$; unit weight $\gamma_a := 28.7\text{plf}$; length $l_a := 6\text{in}$; weight $W_{wr3} := q_a \times \gamma_a \times l_a = 43.05\text{ lbf}$

Skimmer - 120" diameter 12 gauge corrugated metal pipe

unit weight $\gamma_{cmp} := 183\text{plf}$; length $l_{cmp} := 5\text{ft}$; weight $W_{s1} := \gamma_{cmp} \times l_{cmp} = 915\text{ lbf}$

Skimmer - L2.5x2.5x3/8 angle

unit weight $\gamma_{a1} := 5.9\text{plf}$; length $l_{a1} := 23\text{ft}$; weight $W_{s2} := \gamma_{a1} \times l_{a1} = 135.7\text{ lbf}$

Skimmer - L3x3x3/8 angle

unit weight $\gamma_{a2} := 7.2\text{plf}$; length $l_{a2} := 67\text{ft}$; weight $W_{s3} := \gamma_{a2} \times l_{a2} = 482.4\text{ lbf}$

Skimmer - L4x4x3/8 angle

unit weight $\gamma_{a3} := 9.8\text{plf}$; length $l_{a3} := 8\text{ft}$; weight $W_{s4} := \gamma_{a3} \times l_{a3} = 78.4\text{ lbf}$

Weight of skimmer and weir ring plus 1% for miscellaneous steel

$$W_{skmr} := (1 + 1\%) \times (W_{wr1} + W_{wr2} + W_{wr3} + W_{s1} + W_{s2} + W_{s3} + W_{s4}) = 1.894\text{ kip}$$

Floatation Stability - Usual Load Condition

Floatation stability evaluation is based on current criteria published in U.S. Army Corps of Engineers (USACE) EM 1110-2-2100, Stability Analysis of Concrete Structures. For floatation stability, the following minimum allowable safety factors for the usual and unusual loading conditions are required.

Table 1: Floatation Stability Minimum Allowable Factor of Safety

Load Condition	Minimum allowable factor of safety
Usual Load Condition	$FS_{FL_u} := 1.3$
Unusual Load Condition	$FS_{FL_un} := 1.2$

Weight of structure $W_s := W_{ftg} + W_{box} + W_{rsr} + W_{skmr} = 30.431 \text{ kip}$
 Weight of water contained within structure $W_c := 0 \text{ kip}$ (Assume worse case with no water in structure)
 Surcharge loads $S := 0 \text{ kip}$
 Weight of water above top surface of structure $W_G := 0 \text{ kip}$

Calculate uplift force
 Weight of water displaced by foundation $W_{wd_ftg} := \gamma_w \times V_{ftg} = 3.955 \text{ kip}$
 Weight of water displaced by junction box $W_{wd_box} := \gamma_w \times B_{box}^2 \times h_{box} = 8.986 \text{ kip}$
 Weight of water displaced by riser pipe & concrete spillway structure extension $W_{wd_rsr} := \gamma_w \times B_{box}^2 \times h_{rsr} = 4.493 \text{ kip}$
 Uplift force $U := W_{wd_ftg} + W_{wd_box} + W_{wd_rsr} = 17.433 \text{ kip}$

Floatation stability safety factor $FS_{FL} := \frac{W_s + W_c + S}{U - W_G} = 1.75$ must be $\geq FS_{FL_u} = 1.3$

Check floatation safety factor for Usual Load Condition

$checkFS_{FL} := \begin{cases} \text{"Satisfactory"} & \text{if } FS_{FL} \geq FS_{FL_u} \\ \text{"No Good"} & \text{otherwise} \end{cases} = \text{"Satisfactory"}$

Bearing Capacity - Usual Load Condition

The bearing capacity evaluation is based on current criteria published in U.S. Army Corps of Engineers (USACE) EM 1110-2-2100, Stability Analysis of Concrete Structures. For bearing capacity, the following minimum allowable safety factors for the usual and unusual loading conditions are required.

Table 2: Bearing Capacity Minimum Allowable Factor of Safety

<u>Load Condition</u>	<u>Minimum allowable factor of safety</u>
Usual Load Condition	$FS_{BC_u} := 3.0$
Unusual Load Condition	$FS_{BC_un} := 2.6$

Recall foundation soil parameters

Unit weight of foundation soil $\gamma_s = 100 \text{ pcf}$

Friction angle of foundation soil $\phi_s = 26^\circ$

Cohesion of foundation soil $c_s = 0 \text{ psf}$

Recall foundation dimensions

Foundation - width of footing $B_{ftg} = 6.5 \text{ ft}$

Foundation - length of footing $L_{ftg} = 6.5 \text{ ft}$

Foundation - depth of footing $D_{ftg} = 1.5 \text{ ft}$

Depth to base of foundation $D := 794.5 \text{ ft} - EL_{bot} + D_{ftg} = 3.44 \text{ ft}$

Depth from ground surface to water $D_w := 0 \text{ ft}$

Inclined load angle $\theta := 0^\circ$

Bearing Capacity and Correction Factors based on USACE EM 1110-1-1905, Table 4-3

$$N_\phi := \tan^2 \left(45^\circ + \frac{\phi_s}{2} \right) = 2.561$$

$$N_q := N_\phi \times e^{\pi \tan(\phi_s)} = 11.854$$

$$N_c := (N_q - 1) \times \cot(\phi_s) = 22.254$$

$$N_\gamma := (N_q - 1) \times \tan(1.4 \times \phi_s) = 8.002$$

Shape factors

$$\text{cohesion } \zeta_{cs} := 1 + 0.2 \times N_\phi \times \frac{B_{ftg}}{L_{ftg}} = 1.512 ; \text{ wedge } \zeta_{\gamma s} := 1 + 0.1 \times N_\phi \times \frac{B_{ftg}}{L_{ftg}} = 1.256 ;$$

$$\text{surcharge } \zeta_{qs} := 1 + 0.1 \times N_\phi \times \frac{B_{ftg}}{L_{ftg}} = 1.256$$

Bearing Capacity - Usual Load Condition (continued)

Inclined loading factors

$$\text{cohesion } \zeta_{ci} := \frac{\alpha}{\bar{c}} - \frac{\theta}{90^\circ} \frac{\bar{\sigma}}{\phi} = 1 ; \text{ wedge } \zeta_{\gamma i} := \frac{\alpha}{\bar{c}} - \frac{\theta}{\phi_s} \frac{\bar{\sigma}}{\phi} = 1 ; \text{ surcharge } \zeta_{qi} := \frac{\alpha}{\bar{c}} - \frac{\theta}{\phi_s} \frac{\bar{\sigma}}{\phi} = 1$$

Foundation depth factors

$$\text{cohesion } \zeta_{cd} := 1 + 0.2 \times N_\phi^2 \times \frac{D}{B_{ftg}} = 1.169 ; \text{ wedge } \zeta_{\gamma d} := 1 + 0.1 \times N_\phi^2 \times \frac{D}{B_{ftg}} = 1.085 ;$$

$$\text{surcharge } \zeta_{qd} := 1 + 0.1 \times N_\phi^2 \times \frac{D}{B_{ftg}} = 1.085$$

Correction factors

$$\text{cohesion } \zeta_c := \zeta_{cs} \times \zeta_{ci} \times \zeta_{cd} = 1.768 ; \text{ wedge } \zeta_\gamma := \zeta_{\gamma s} \times \zeta_{\gamma i} \times \zeta_{\gamma d} = 1.362 ; \text{ surcharge } \zeta_q := \zeta_{qs} \times \zeta_{qi} \times \zeta_{qd} = 1.362$$

$$\text{Ultimate bearing capacity } q_u := c_s \times N_c \times \zeta_c + \frac{1}{2} \times B_{ftg} \times (\gamma_s - \gamma_w) \times N_\gamma \times \zeta_\gamma + (\gamma_s - \gamma_w) \times D \times N_q \times \zeta_q = 3.421 \text{ ksf}$$

$$\text{Net bearing capacity } q_{net} := q_u - (\gamma_s - \gamma_w) \times D = 3.292 \text{ ksf}$$

$$\text{Weight of structure } W_s = 30.431 \text{ kip}$$

Weight of water contained within structure (Assume worst case with water filled in structure)

$$\text{Weight of water inside junction box } W_{wc_box} := \gamma_w \times (B_{box} - 2 \times h_{box})^2 \times h_{box} = 3.994 \text{ kip}$$

$$\text{Weight of water inside riser } W_{wc_rsr} := \gamma_w \times \frac{\pi}{4} \times D_{rsr}^2 \times h_{rsr} = 1.568 \text{ kip}$$

$$\text{Total weight of water contained in structure } W_C := W_{wc_box} + W_{wc_rsr} = 5.562 \text{ kip}$$

$$\text{Total applied pressure (ignoring uplift pressure) } q_{applied} := \frac{W_s + W_C}{B_{ftg} \times L_{ftg}} = 0.852 \text{ ksf}$$

$$\text{Bearing capacity safety factor } FS_{BC} := \frac{q_{net}}{q_{applied}} = 3.86 \text{ must be } \geq FS_{BC_u} = 3$$

Check bearing capacity for Usual Load Condition

$$\text{checkFS}_{BC} := \begin{cases} \text{"Satisfactory"} & \text{if } FS_{BC} \geq FS_{BC_u} \\ \text{"No Good"} & \text{otherwise} \end{cases} = \text{"Satisfactory"}$$

Sliding Stability- Unusual Load Condition

The sliding stability evaluation is based on current criteria published in U.S. Army Corps of Engineers (USACE) EM 1110-2-2100, Stability Analysis of Concrete Structures. For sliding stability, the following minimum allowable safety factors for the usual and unusual loading conditions are required.

Table 3: Sliding Stability Minimum Allowable Factor of Safety

Load Condition	Minimum allowable factor of safety
Usual Load Condition	$FS_{SL_u} := 2.0$
Unusual Load Condition	$FS_{SL_un} := 1.5$

Calculate lateral drag force on side of riser structure. For submerged condition, the riser is assumed to be subjected to flood water flow.

Assumed maximum flood water velocity $V_{max} := 6 \frac{ft}{s}$

Drag coefficient $C_D := 1.25$ (USACE - drag coefficient not less than 1.25)

Density of water $\rho := 1.937 \frac{slug}{ft^3}$

Height of riser structure with skimmer $H_{eff} := H_{structure} + 3ft = 9.24ft$ (skimmer top is 3' above riser top)

Frontal area (face of riser)

$$A_{fa} := B_{box} \times h_{box} + B_{box} \times h_{rsr} + 10ft \times h_{cmp} = 86ft^2$$

Lateral drag force on riser $F_D := C_D \frac{1}{2} \rho V_{max}^2 A_{fa} = 3.748kip$

Normal force $F_N := W_s + W_C + S + W_G - U = 18.56kip$

Sliding stability safety factor $FS_{SL} := \frac{c_s \times B_{fig} \times L_{fig} + F_N \times \tan(\phi_s)}{F_D} = 2.42$ must be $\geq FS_{SL_un} = 1.5$

Check sliding stability for Unusual Load Condition

$$checkFS_{SL} := \begin{cases} \text{"Satisfactory"} & \text{if } FS_{SL} \geq FS_{SL_un} \\ \text{"No Good"} & \text{otherwise} \end{cases} = \text{"Satisfactory"}$$

Overturning Stability- Unusual Load Condition

The overturning stability evaluation is based on current criteria published in U.S. Army Corps of Engineers (USACE) EM 1110-2-2100, Stability Analysis of Concrete Structures. For overturning stability, the following criteria for the usual and unusual loading conditions are required.

Table 4: Overturning Stability Acceptance criteria

Load Condition	Acceptance criteria
Usual Load Condition	100% base in compression
Unusual Load Condition	75% base in compression, resultant within base

Overturning moment due to lateral drag force $M_D := F_D \times \frac{H_{eff}}{2} = 17.316 \times \text{ft} \times \text{kip}$

Eccentricity (resultant from center of foundation) $ecc := \frac{M_D}{F_N} = 0.933 \text{ ft}$

check if eccentricity is within middle 1/3 of foundation $\frac{B_{ftg}}{6} = 1.083 \text{ ft}$

check_{ecc} := $\begin{cases} \text{"100% base in compression"} & \text{if } ecc \leq \frac{B_{ftg}}{6} \\ \text{"Less than 100% base in compression"} & \text{otherwise} \end{cases} = \text{"100% base in compression"}$

Sum moments about toe of riser $M_o := -M_D + F_N \times \frac{B_{ftg}}{2} = 43.002 \times \text{ft} \times \text{kip}$

Resultant distance from toe of riser $x_R := \frac{M_o}{F_N} = 2.317 \text{ ft}$

Resultant ratio $x_{R_ratio} := \frac{x_R}{B_{ftg}} = 0.356$

Base area in compression (USACE EM 1110-2-2502, Figure 4-4) $base_c := 3 \times x_{R_ratio} = 107\%$

Check overturning percent base in compression acceptance criteria for Unusual Load Condition

check_{base_c} := $\begin{cases} \text{"Satisfactory"} & \text{if } base_c \geq 75\% \\ \text{"No Good"} & \text{otherwise} \end{cases} = \text{"Satisfactory"}$

Check overturning resultant acceptance criteria for Unusual Load Condition

check_{rslt} := $\begin{cases} \text{"Satisfactory, resultant within base"} & \text{if } 0 \text{ft} \leq x_R \leq B_{ftg} \\ \text{"No good, resultant outside base"} & \text{otherwise} \end{cases} = \text{"Satisfactory, resultant within base"}$

Bearing Capacity - Unusual Load Condition

Maximum bearing pressure for $e < \frac{B_{ftg}}{6}$ $Q_{max} := \frac{2F_N}{3L_{ftg} \left(\frac{B_{ftg}}{e} - \frac{e}{B_{ftg}} \right)} = 0.822 \text{ ksf}$

Bearing capacity safety factor $FS_{bc} := \frac{q_{net}}{Q_{max}} = 4.01$ must be $\geq FS_{BC_un} = 2.6$

Check bearing capacity for Unusual Load Condition

$$check_{FS_{bc}} := \begin{cases} \text{"Satisfactory"} & \text{if } FS_{bc} \geq FS_{BC_un} \\ \text{"No Good"} & \text{otherwise} \end{cases} = \text{"Satisfactory"}$$

Check Riser Does Not Tip Over - Unusual Load Condition

Overturning moment due to lateral drag force $M_{o_LD} := F_D \left(\frac{H_{eff}}{2} \right) = 17.316 \text{ ft}\cdot\text{kip}$

Resisting moment from weight of riser and skimmer $M_T := (W_{skmr} + W_{rsr}) \left(\frac{OD_{rsr}}{2} \right) = 20.824 \text{ ft}\cdot\text{kip}$

Check riser does not tip over for Unusual Load Condition

$$check_{riser} := \begin{cases} \text{"Satisfactory, riser does not tip over"} & \text{if } M_T \geq M_{o_LD} \\ \text{"No Good"} & \text{otherwise} \end{cases} = \text{"Satisfactory, riser does not tip over"}$$

Check Shear and Maximum Moment in Risers - Unusual Load Condition

Define load and resistance factors based on ACI 350 (conservatively use plain concrete values)
 shear reduction factor $\phi_c := 0.55$; bending moment reduction factor $\phi_b := 0.55$

load factor for fluids FL := 1.4

Maximum factored shear load $V_u := FL \times F_D = 5.247 \text{ kip}$

Shear capacity of riser $V_c := \phi_c \times 0.10 \times f_c \times A_{rsr} = 107.819 \text{ kip}$

check shear capacity $\text{check}V_c := \begin{cases} \text{"Satisfactory"} & \text{if } V_c \geq V_u \\ \text{"No good"} & \text{otherwise} \end{cases}$

Maximum factored moment load $M_u := FL \times M_{o_LD} = 24.243 \text{ ft} \cdot \text{kip}$

Section modulus of riser $S_{x_rsr} := \frac{\frac{\pi}{64} \times OD_{rsr}^4 - ID_{rsr}^4}{\frac{OD_{rsr}}{2}} = 4.592 \text{ ft}^3$

Moment capacity in compression $M_{cc} := \phi_b \times f_c \times S_{x_rsr} = 1091.03 \text{ ft} \cdot \text{kip}$

Moment capacity in tension $M_{ct} := \phi_b \times f_t \times S_{x_rsr} = 128.601 \text{ ft} \cdot \text{kip}$

check moment capacity $\text{check}M_c := \begin{cases} \text{"Satisfactory"} & \text{if } \min(M_{cc}, M_{ct}) \geq M_u \\ \text{"No good"} & \text{otherwise} \end{cases}$

Check Shear and Maximum Moment in Pipes - Usual Condition

Inner diameter of pipe, $ID_p := 36\text{in}$

Wall thickness of pipe, $t_{wp} := 4\text{in}$

Outer diameter of pipe, $OD_p := ID_p + 2 \times t_{wp} = 44\text{in}$

Area of pipe, $A_p := \frac{\pi}{4} \times OD_p^2 - ID_p^2 = 3.491\text{ft}^2$

Unit weight of dike embankment, $\gamma_{emb} := 120\text{pcf}$

Height of dike embankment, $H_{emb} := 15\text{ft}$

Depth from top of dike to water level, $dw := 10.7\text{ft}$ (top of dike at EL 811', normal pool at EL 800.3')

Vertical arching factor, $VAF := 1.45$

Effective length of pipe, $L_e := 1\text{ft}$

Load due to earth pressure, $W_e := VAF \times \gamma_{emb} \times OD_p \times H_{emb} = 9.57 \frac{\text{kip}}{\text{ft}}$

Force from earth pressure, $F_{W_e} := W_e \times L_e = 9.57 \text{kip}$

Load due to water, $W_D := \gamma_w \times OD_p \times (H_{emb} - dw) = 0.984 \frac{\text{kip}}{\text{ft}}$

Force from water, $F_{D_p} := W_D \times L_e = 0.984 \text{kip}$

Moment load due to earth pressure, $M_{o_Fwe} := \frac{W_e \times L_e^2}{8} = 1.196 \text{ft} \times \text{kip}$

Moment load due to water, $M_{o_Fdp} := \frac{W_D \times L_e^2}{8} = 0.123 \text{ft} \times \text{kip}$

Define load and resistance factors based on ACI 350 (conservatively use plain concrete values)
 shear reduction factor $\phi_c = 0.55$; bending moment reduction factor $\phi_b = 0.55$

Maximum factored shear load

$$V_{u_p} := \max(1.4 \times F_{D_p}, 1.2 \times F_{D_p} + 1.6 \times F_{W_e}) = 16.493 \text{kip}$$

Shear capacity of pipe

$$V_{c_p} := \phi_c \times 0.10 \times A_p = 82.938 \text{kip}$$

check shear capacity

$$\text{check } V_{c_p} := \begin{cases} \text{"Satisfactory"} & \text{if } V_{c_p} \geq V_{u_p} \\ \text{"No good"} & \text{otherwise} \end{cases}$$

Maximum factored moment load

$$M_{u_p} := \max(1.4 \times M_{o_Fdp}, 1.2 \times M_{o_Fdp} + 1.6 \times M_{o_Fwe}) = 2.062 \text{ft} \times \text{kip}$$

Section modulus of riser

$$S_{x_p} := \frac{\frac{\pi}{64} \times OD_p^4 - ID_p^4}{\frac{OD_p}{2}} = 2.671 \text{ft}^3$$

Moment capacity in compression $M_{cc_p} := \phi_b \times S_{x_p} = 634.602 \text{ft} \times \text{kip}$

Moment capacity in tension

$$M_{ct_p} := \phi_b \times S_{x_p} = 74.801 \text{ft} \times \text{kip}$$

check moment capacity

$$\text{check } M_{c_p} := \begin{cases} \text{"Satisfactory"} & \text{if } \min(M_{cc_p}, M_{ct_p}) \geq M_{u_p} \\ \text{"No good"} & \text{otherwise} \end{cases}$$

Check Shear and Maximum Moment in Pipes - Unusual Condition

Depth from top of dike to water level, $dw_{un} := 3\text{ft}$ (top of dike at EL 811', flood pool at EL 808')
 (Conservatively assumes 3' freeboard)

$$\text{Load due to water, } W_{D_{un}} := \gamma_w \times OD_p \times (H_{emb} - dw_{un}) = 2.746 \times \frac{\text{kip}}{\text{ft}}$$

$$\text{Force from water, } F_{D_{p_{un}}} := W_{D_{un}} \times L_e = 2.746 \times \text{kip}$$

$$\text{Moment load due to earth pressure, } M_{O_{Fwe}} = 1.196 \times \text{ft} \times \text{kip}$$

$$\text{Moment load due to water, } M_{O_{Fdp_{un}}} := \frac{W_{D_{un}} \times L_e^2}{8} = 0.343 \times \text{ft} \times \text{kip}$$

Define load and resistance factors based on ACI 350 (conservatively use plain concrete values)
 shear reduction factor $\phi_c = 0.55$; bending moment reduction factor $\phi_b = 0.55$

$$\text{Maximum factored shear load } V_{u_{p_{un}}} := \max(1.4 \times F_{D_{p_{un}}}, 1.2 \times F_{D_{p_{un}}} + 1.6 \times F_{W_e}) = 18.607 \times \text{kip}$$

$$\text{Shear capacity of pipe } V_{c_{p}} = 82.938 \times \text{kip}$$

$$\text{check shear capacity } \text{check} V_{c_{p_{un}}} := \begin{cases} \text{"Satisfactory"} & \text{if } V_{c_{p}} \geq V_{u_{p_{un}}} \\ \text{"No good"} & \text{otherwise} \end{cases} = \text{"Satisfactory"}$$

Maximum factored moment load

$$M_{u_{p_{un}}} := \max(1.4 \times M_{O_{Fdp_{un}}}, 1.2 \times M_{O_{Fdp_{un}}} + 1.6 \times M_{O_{Fwe}}) = 2.326 \times \text{ft} \times \text{kip}$$

$$\text{Moment capacity in compression } M_{cc_{p}} = 634.602 \times \text{ft} \times \text{kip}$$

$$\text{Moment capacity in tension } M_{ct_{p}} = 74.801 \times \text{ft} \times \text{kip}$$

check moment capacity

$$\text{check} M_{c_{p_{un}}} := \begin{cases} \text{"Satisfactory"} & \text{if } \min(M_{cc_{p}}, M_{ct_{p}}) \geq M_{u_{p_{un}}} \\ \text{"No good"} & \text{otherwise} \end{cases} = \text{"Satisfactory"}$$

APPENDIX B

IMAGES



Image 1. Video inspection of outlet pipe from middle riser in Stilling Pond 2C, view looking towards spillway riser showing minor encrustation and minimal leaking.